

VI. Water Polo Rules

- 1. THE FIELD OF PLAY & EQUIPMENT**
- 2. TEAMS & PLAYERS**
- 3. REFEREES AND TECHNICAL OFFICIALS**
- 4. DURATION OF THE GAME**
- 5. TIMEOUTS**
- 6. START AND RESTART OF PLAY**
- 7. METHOD OF SCORING**
- 8. ORDINARY FOULS**
- 9. EXCLUSION FOULS**
- 10. PENALTY FOULS**
- 11. FREE THROWS**
- 12. GOAL THROWS**
- 13. CORNER THROWS**
- 14. NEUTRAL THROWS**
- 15. PENALTY THROWS**
- 16. PERSONAL FOULS, YELLOW AND RED CARDS**
- 17. ACCIDENT, INJURY AND ILLNESS**
- 18. WATER POLO FACILITIES**
- 19. APPENDICIES**
- 20. BEACH WATER POLO RULES**

1. THE FIELD OF PLAY & EQUIPMENT

- 1.1 Features of the field of play, goals, ball and other equipment must be in accordance with Appendix 4.
- 1.2 The distance between the goal lines shall not be less than 20 metres and not more than 30 metres for games played by men. The distance between the goal lines shall not be less than 20 metres and not more than 25 metres for games played by women. The width of the field of play shall be not less than 10 metres and not more than 20 metres.
- 1.3 An area for flying substitutions must be available on the lateral outer side of the field of play, on the side where the team benches are situated. The width of this area must be between 0.5m – 1m. The designated area for flying substitutions for each team will be between the goal line in front of the team bench and the centre of the field of play.

2. TEAMS & PLAYERS

Team composition

- 2.1 Each team must consist of a maximum of thirteen players: eleven field players and two goalkeepers. A team must start the game with not more than seven players, one of whom shall be the goalkeeper and who shall wear the goalkeeper's cap. Five reserves may be used as substitutes and one reserve goalkeeper who may be used only as a substitute goalkeeper. A team playing with less than seven players shall not be required to have a goalkeeper. If a team has no more substitutes apart from the substitute goalkeeper, either the goalkeeper or substitute goalkeeper, if applicable, may play as a field player.
- 2.2 All players not in the game at that time, together with the coaches and officials except for the head coach, must sit on the team bench and shall not move away from the bench from the commencement of play, except for substitutions and during the intervals between periods or during timeouts. The head coach of the attacking team may move to the 6 metre line at any time. Teams must only change ends and benches at half time. The team benches must both be situated on the side opposite to the official table.
- 2.3 The captains shall be playing members of their respective teams and, together with the head coach, they shall be responsible for the good conduct and discipline of the team.
- 2.4 Players shall wear non-transparent costumes or costumes with a separate undergarment and before taking part in a game shall remove any articles likely to cause injury.
- 2.5 Players shall not have grease, oil or any substance on the body, which might provide an advantage. If a referee determines before the start of play that such a substance has been used, the referee shall order it to be removed immediately. The start of play shall not be delayed for the substance to be removed. If the offence is detected after the play has started, the offending player shall be excluded from the remainder of the game and a substitute permitted to enter the field of play immediately from the team's exclusion re-entry area.

Substitution procedure

- 2.6 At any time in the game, a player or goalkeeper may be substituted by leaving the field of play at the team's exclusion re-entry area. The substitute may enter the field of play from the exclusion re-entry area as

soon as the player has visibly risen to the surface of the water within the re-entry area and touched hands above the water with the substitute. Substitution from the 'flying substitution' area is also allowed when the substitute enters the area from behind the extended goal line, both players, the exiting player and the substitute, are in the water, outside of the field of play and touch hands above the water. A substitute shall be ready to replace a player, without delay. If the substitute is not ready, the game shall continue without the substitute and, at any time, the substitute may then enter the field of play from the team's designated substitution areas, after touching hands where applicable.

- 2.7 If a goalkeeper is substituted under this Rule, it must only be by the substitute goalkeeper, if applicable. No substitution shall be made under this Rule between the time a referee awards a penalty throw and the taking of the throw or during VAR review. If the goalkeeper or substitute goalkeeper, if applicable, is not entitled or able to participate, a team playing with seven players shall be required to play with an alternative goalkeeper who shall wear the goalkeeper's cap. A goalkeeper who has been replaced by a substitute may not play in any position other than goalkeeper.
- 2.8 No substitution shall be made, except for bleeding, between the time a referee awards a penalty throw and the taking of the throw or during VAR review.
- 2.9 A substitute may enter the field of play from any place: (a) during the intervals between periods of play; (b) after a goal has been scored; (c) during a timeout; (d) to replace a player who is bleeding or injured.
- 2.10 If a player, on the player's own initiative, leaves the field of play for other than a substitution from the designated lateral substitution area in a place other than the exclusion re-entry area or the designated lateral substitution area, this player will not be punished for leaving the field of play and this player or a substitute will be able to (re-)enter the field of play from the exclusion re-entry area only with permission of the referee. The player may also re-enter after a goal, after a timeout or at the start of the next period.

3. REFEREES AND TECHNICAL OFFICIALS

- 3.1 For World Aquatics events, the officials shall consist of two referees, two assistant referees, timekeepers and secretaries and a video assistant referee, each with the powers and duties specified in Appendix 5 and following the procedures specified in Appendix 7, if applicable.
- 3.2 To enforce the Rules, the referees shall be in absolute control of the game and their authority over players, team officials and spectators shall be effective from the moment they enter until they leave the venue of the match.
- 3.3 The referees shall have the power:
- (i) to award or not award any ordinary, exclusion or penalty foul, while encouraging action and the advantage of the attacking team. A referee may award a foul or refrain from awarding a foul if awarding the foul would be an advantage to the offending player's team;
 - (ii) to order the removal from the precincts of the pool or the venue any player, substitute, spectator or official whose behaviour prevents the referees from carrying out their duties in a proper and impartial manner;
 - (iii) to abandon the game at any time if the behaviour of the players or spectators, or other circumstances prevent it from being brought to a

proper conclusion.

4. DURATION OF THE GAME

- 4.1 The duration of the game shall be four periods each of eight minutes actual play. Time shall commence at the start of each period when a player touches the ball. At all signals for stoppages, the time shall be stopped until the ball is put back into play by the ball leaving the hand of the player taking the appropriate throw or until the ball is touched by a player following a neutral throw.
- 4.2 There shall be a two-minute interval between the first and second periods and between the third and fourth periods and a three-minute interval between the second and third periods. The teams, including the players, coaches and officials, shall change ends before starting the third period.
- 4.3 Each World Aquatics Water Polo game shall have a winner at full time in any game. There shall be a penalty shoot out to determine the result as specified in Appendix 6
- 4.4 If a game (or part of a game) must be replayed, then goals, personal fouls, and timeouts that occurred during the time to be replayed are deleted from the game score sheet, however exclusions for violent action, misconduct, and any red card exclusions are recorded on the game score sheet.

5. TIMEOUTS

- 5.1 Each team may request two timeouts per game. The duration of the timeout shall be one minute. A timeout may be requested at any time, including after a goal, but not after a penalty throw has been awarded or during VAR review, by the coach of the team in possession of the ball calling "timeout" and signalling to the secretary or referee with the hands forming a T-shape. A team has possession of the ball when one of its players is holding or swimming with the ball. If a timeout is requested, the secretary or referee shall immediately stop the game by whistle and the players shall immediately return to their respective halves of the field of play. The timeout request can also be made by any device authorized for use in the game.
- 5.2 Play shall be restarted on the whistle of the referee by the team in possession of the ball putting the ball into play on or behind the half distance line, except that if the timeout is requested before the taking of a corner throw, that throw shall be maintained.
- 5.3 If the coach of the team in possession of the ball requests an additional timeout to which the team is not entitled, the game shall be stopped, and play shall then be restarted by a player of the opposing team putting the ball into play at the half distance line.
- 5.4 If the coach of the team not in possession of the ball requests a timeout, the game shall be stopped, and a penalty throw awarded to the opposing team. After requesting this illegal timeout, the coach shall lose the right to request a legal timeout if the team still has one.
- 5.5 At the restart following a timeout, players may take any position in the field of play, subject to the Rules relating to the taking of corner throws.

6. START AND RESTART OF PLAY

- 6.1 The first team listed in the official program will wear white caps or the caps

reflecting the colour of their country and will start the game to the left of the official table. The other team will wear blue caps or caps of a contrasting colour and will start the game to the right of the table.

- 6.2 At the start of each period, the players must take up positions on their respective goal lines, about one metre apart and at least one metre from the goal posts. Not more than two players shall be allowed between the goal posts. No part of a player's body shall be beyond the goal line at water level.
- 6.3 When the referees are satisfied that the teams are ready, a referee shall blow the whistle to start and then release or throw the ball into play on the half distance line.
- 6.4 After a goal has been scored, the players shall take up positions anywhere within their respective halves of the field of play. No part of a player's body shall be beyond the half distance line at water level. A referee shall restart the game by blowing the whistle. At the time of the restart, actual play shall resume when the ball leaves the hand of a player of the team not having scored the goal. A restart not taken in accordance with this Rule shall be retaken.

7. METHOD OF SCORING

- 7.1 A goal shall be scored when the entire ball has passed fully over the goal line, between the goal posts and underneath the crossbar. The goal line is an imaginary laser line which runs on the front side from one goal post to the other post. A goal is scored when the ball fully passed the goal line as in position D and may be scored from anywhere within the field of play by any part of the body except a clenched fist.

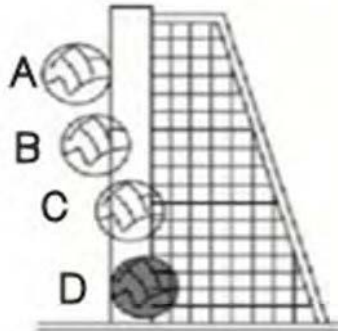

- 7.2 A goal may be scored:
- at the start or any restart of the game, after at least two players (of either team but excluding the defending goalkeeper) intentionally play or touch the ball;
 - from a penalty throw;
 - if a player throws the ball from a free throw into the player's own goal;
 - from an immediate shot from a goal throw or a corner throw or a free throw awarded outside 6 metres;
 - by a player who visibly puts the ball into play when starting or restarting play outside 6 metres:
 - after a swim up or the commencement of a period;
 - after a timeout or a goal;

- iii. after an injury;
- iv. after replacement of a cap;
- v. after the referee calls for the ball or calls for a neutral throw;
- vi. when the ball leaves the side of the field of play;
- vii. taking a free throw awarded outside 6 metres;
- viii. after any other delay.

7.3 A goal shall be scored if, at the expiration of 20 or 30 seconds possession or at the end of a period, the ball is in flight or moving toward the goal and enters the goal, including after bouncing off the water, hitting the goal post, crossbar, goalkeeper, or another player, except when intentionally played or touched by another attacking player.

8. ORDINARY FOULS

8.1 It shall be an ordinary foul to commit any of the following offences (VI.8.2 to VI.8.15), which shall be punished by awarding of a free throw to the opposing team, except as otherwise provided by the Rules.

8.2 To advance beyond the goal line at the start of a period, before the referee has given the signal to start. The free throw shall be taken from the location of the ball or, if the ball has not been released into the field of play, from the half distance line.

8.3 To assist a player at the start of a period or at any other time during the game.

8.4 To hold or push off from the goal posts or their fixtures, to hold or push off from the sides or ends of the pool during actual play or at the start of a period.

8.5 To take any active part in the game when standing on the floor of the pool, to walk when play is in progress or to jump from the floor of the pool to play the ball or tackle an opponent. This rule shall not apply to the goalkeeper while within the goalkeeper's 6 metre area.

8.6 To take or hold the entire ball under the water when tackled or to deliberately hide it from the opposing team.

8.7 To strike at the ball with a clenched fist, unless by the goalkeeper while within the 6 metre area.

8.8 To play or touch the ball with two hands at the same time, unless by the goalkeeper while within the 6 metre area.

8.9 To push or push off from an opponent who is not holding the ball.

8.10 To be within the opponent's goal area except when behind the line of the ball. It shall not be an offence if a player is inside the 2 metre line but outside the goal area. Any player who is behind the line of the ball can enter the goal area to receive the ball. Any player inside the goal area who does not shoot but passes the ball backwards has to leave the goal area immediately to avoid being sanctioned under this rule.

8.11 To take a free throw, goal throw, corner throw or a penalty throw other than in the prescribed manner except under the circumstances provided by VI 12.2 and VI13.4.

8.12 For a team to retain possession of the ball without shooting at the opponent's goal for more than: (i) 30 seconds of actual play, or (ii) 20 seconds in the case of an exclusion, corner throw or rebound to the

attacking team after a shot, including after a penalty shot.

The timekeeper recording the possession time shall reset the clock:

- (a) when the ball has left the hand of the player shooting at goal. If the ball rebounds into play from the goal post, crossbar, a player or the goalkeeper, the possession time shall not recommence until the ball comes into the possession of one of the teams. The clock shall be reset to 20 seconds if the ball comes into possession of the attacking team. It shall be reset to 30 seconds if it comes into possession of the defending team;
- (b) when the ball comes into the possession of the defending team, the clock shall be reset to 30 seconds.
- (c) when the ball is put into play following the award of an exclusion foul to the defending player, the clock shall be reset to 20 seconds unless there are more than 20 seconds of possession time remaining, in which case the time shall continue and not be reset;
- (d) when the ball is put into play following the taking of a penalty throw without a change of possession or, corner throw, the clock shall be reset to 20 seconds;
- (e) when the ball is put into play following the award of a penalty throw with a change of possession, a goal throw or neutral throw, the clock shall be reset to 30 seconds. Visible clocks shall show the time in a descending manner (that is, showing the possession time remaining).

8.13 To waste time.

8.14 To simulate being fouled.

8.15 To go under the water to gain positional advantage.

9. EXCLUSION FOULS

9.1 It shall be an exclusion foul to commit any of the following offences (VI 9.4 to VI9.18) which shall be punished (except as otherwise provided by the Rules) by the award of a free throw to the opposing team and the exclusion of the player who committed the foul.

9.2 An excluded player, including a player excluded for the remainder of the game, must immediately leave the field of play, not leaving the water, and move to the exclusion re-entry area (visibly rising to the surface of the water and, if applicable, touch hands above the water with the substitute) nearest to the player's own goal line without interfering with the play.

9.3 The excluded player or a substitute shall be permitted to re-enter the field of play from the re-entry area nearest to the player's own goal line after the earliest occurrence when:

- (a) 20 seconds of actual play have elapsed, at which time the secretary shall raise the appropriate flag;
- (b) a goal has been scored; an excluded player or a substitute may re-enter the field of play from any place.
- (c) the excluded player's team has retaken possession of the ball during actual play, at which time the defensive referee shall signal re-entry by a hand signal;

- (d) the excluded player's team is awarded a free throw, a goal throw or a penalty throw.

The excluded player or a substitute shall not be permitted to:

- (i) jump or push off from the side or wall of the pool or the field of play;
- (ii) affect the alignment of the goal;
- (iii) enter for an excluded player until that player has reached the exclusion re-entry area nearest to the player's own goal line except between periods, after a goal, or during a timeout.

These provisions shall also apply to the entry of a substitute when the excluded player has received three personal fouls or has otherwise been excluded from the remainder of the game in accordance with the Rules.

- 9.4 For a player to leave the water or sit or stand on the steps or side of the pool during play, except in the case of accident, injury, illness or with the permission of a referee. An excluded player who leaves the water (other than following the entry of a substitute) shall be deemed guilty of an offence under VI.9.13 (Misconduct).
- 9.5 To interfere with the taking of a free throw, goal throw or corner throw, including: (a) intentionally to throw away or fail to release the ball to prevent the normal progress of the game; (b) any attempt to play the ball before it has left the hand of the thrower.
- 9.6 To attempt to block a pass or shot with two hands outside the 6 metre area.
- 9.7 To intentionally splash in the face of an opponent.
- 9.8 To impede or otherwise prevent the free movement of an opponent who is not holding the ball, including swimming on the opponent's shoulders, back or legs. "Holding" is lifting, carrying or touching the ball but does not include dribbling the ball.
- 9.9 To hold, sink or pull back an opponent who is not holding the ball.
- 9.10 Anywhere in the field of play, to use two hands to hold an opponent not holding the ball.
- 9.11 Tactical foul. Anywhere in the field of play, for a defending player to commit a foul on any player of the team in possession of the ball with the intent to stop the flow of the attack. This kind of foul is called a tactical foul.
- 9.12 To make disproportionate movements including kicking and striking.
- 9.13 To be guilty of misconduct, including the use of unacceptable language, aggressive play, refusing obedience to or showing disrespect for a referee or official, or behaviour against the spirit of the Rules and likely to bring the game into disrepute.
- 9.13.1 Should this occur during the game, the offending player shall be excluded from the remainder of the game, with substitution after the earliest occurrence referred to in VI.9.3, and must leave the competition area.
- 9.13.2 Should the incident occur during the interval between periods, during a timeout, or after a goal, the player shall be excluded for the remainder of the game and a substitute shall be eligible to re-enter immediately prior to the restart of the game and play will restart in the normal manner.

9.13.3 When one or more players of a team persist in repeated fouls other than aggressive play or misconduct or protest referees' or officials' decisions without the use of unacceptable language, the referee may show a yellow card to the offending team. Should the action continue, the referee will issue the offending player of the same team with a red card excluding the player for the remainder of the game according to VI.9.13 (misconduct).

9.14 To commit a violent action, including kicking, striking, or attempting to kick or strike with malicious intent an opponent or official, whether during actual play, during any stoppages, timeouts, after a goal has been scored or during intervals between periods of play. If the offending player is the goalkeeper, a substitute goalkeeper may be changed for another player in accordance with VI.2.6.

9.14.1 Should this occur during the game, the offending player shall be excluded for the remainder of the game and must leave the competition area and a penalty throw awarded to the opposing team. The offending player may be substituted when four minutes of actual play have elapsed.

9.14.2 Should the incident occur during any stoppage, timeout, after a goal or interval between periods of play, the player shall be excluded for the remainder of the game and must leave the competition area. No penalty throw shall be awarded. The offending player may be substituted when four minutes of actual play have elapsed. Play will restart in the normal manner.

9.14.3 If the referees call violent actions simultaneously on players of opposing teams during play, both players are excluded for the remainder of the game with substitution when four minutes of actual play have elapsed. The team, which had possession of the ball, will first shoot a penalty throw followed by the other team shooting a penalty throw. After the second penalty throw, the team, which had possession of the ball, will restart play with a free throw on or behind the half distance line.

9.15 In the case of simultaneous exclusion of players of opposing teams during play, both players are excluded for 20 seconds until the earliest occurrence referred to in VI.9.3 or at the next change of possession. The possession clock is not reset. Play is restarted with a free throw to the team which had possession of the ball. If neither team had possession when the simultaneous exclusions were called, the possession clock is reset to 30 seconds and play shall be restarted with a neutral throw. Both players excluded under this Rule, shall be permitted to re-enter at the next earliest occurrence referred to in VI.9.3 or at the next change of possession.

9.16 For an excluded player to re-enter or a substitute to enter the field of play improperly, including not following VI.2.6, VI.2.7 and VI.9.3. This player receives only one personal foul, which should be marked by the secretary as an exclusion foul.

9.16.1 If this offence is committed by a player of the team not in possession of the ball, the offending player shall be excluded and a penalty throw also awarded to the opposing team.

9.16.2 If this offence is committed by a player of the team in possession of the ball, the offending player shall be excluded and a free throw awarded to the opposing team.

9.17 To interfere with the taking of a penalty throw. The offending player shall be excluded from the remainder of the game with substitution after the earliest occurrence referred to in VI.9.3 and the penalty throw shall be maintained or re-taken as appropriate. The referees may use the VAR system to determine if there has been interference with the penalty throw.

This offence may occur before the taking of the throw or after the whistle by the referee.

- 9.18 For the defending goalkeeper to fail to take up the correct position on the goal line at the taking of a penalty throw having been ordered once to do so by the referee. Another defending player may take the position of the goalkeeper but without the goalkeeper's privileges or limitations.

10. PENALTY FOULS

- 10.1 It shall be a penalty foul to commit any of the following offences (VI.10.2 to VI.10.11) which shall be punished by the award of a penalty throw to the opposing team. The referee can delay whistling and wait to see if the attacking player scores a goal in the same action. If the player does not score, the referee should sanction the penalty. The referee may raise an arm indicating a possible penalty.
- 10.2 For a goalkeeper or defending player to commit any foul within the 6 metre area if a goal would probably have resulted, including VI.10.4 to VI.10.7.
- 10.3 For an excluded player intentionally to interfere with play, including affecting the alignment of the goal. If the excluded player does not commence leaving the field of play almost immediately, the referee may deem this to be intentional interference under this Rule.
- 10.4 For a goalkeeper or defending player to pull over, pull down or otherwise displace the goal.
- 10.5 Within the 6 metre area, for a defending player to attempt to block a pass or shot with two hands.
- 10.6 Within the 6 metre area, for a defending player to play the ball with a clenched fist.
- 10.7 Within the 6 metre area, for a goalkeeper or defending player to take the ball under the water when tackled.
- 10.8 For a player or substitute who is not entitled under the Rules to participate in the play at that time to enter the field of play. Also, the offending player shall be excluded from the remainder of the game with substitution. The substitute may enter the field of play after the earliest occurrence referred to in VI. 9.3.
- 10.9 For the coach, or any team official, of the team not in possession of the ball to request a timeout. No personal foul shall be recorded for this offence.
- 10.10 For the coach or any team official, or player to take any action with intent to prevent a probable goal or to delay the game, including:
- a) a defending player deliberately throwing the ball away before the attacking team can take a free throw
 - b) a defending player, after a free throw outside the 6 metre line, deliberately pushing the ball inside 6 metre line, to avoid a direct shot.

No personal foul shall be recorded for this offence by the coach or any team official.

- 10.11 For a defending player to impede an attacking player from behind within the 6 metre area when the attacking player is facing the goal and making a shooting action, unless the defending player makes contact only with the ball. If the defending player's foul, described in this Rule, prevents the attacking player from scoring, a penalty must also be called. The referee must delay the call of penalty until the shot or attempted shot is completed and must award a penalty unless the attacking player scores.

- 10.12 If, in the last minute of the game, a penalty throw is awarded to a team, the coach may elect to maintain possession of the ball and be awarded a free throw. The timekeeper recording possession time shall reset the clock to 30 seconds, and the game will be restarted as after a timeout.

It is the responsibility of the coach to give a clear signal without delay if the team wishes to maintain possession of the ball in accordance with this Rule.

11. FREE THROWS

- 11.1 A free throw shall be taken at the location of the ball, unless, after a foul committed by a defending player, the ball is inside the goal area. Then the free throw shall be taken on the 2 metre line opposite to the location of the ball. If the ball is outside of the goal area at the moment that the foul is awarded, the free throw shall be taken from the location of the ball.
- 11.2 A player awarded a free throw must put the ball into play with no undue delay, including by passing or by shooting, if permitted by the Rules. It shall be an ordinary foul if a player who is clearly in a position most readily to take a free throw does not do so. A defending player having committed a foul shall move away not less than 1 metre from the player taking the free throw before raising an arm to block a pass or shot; a player who fails to do so shall be excluded for "interference" under VI.9.5.
- 11.3 The free throw shall be taken with no undue delay by the player nearest to the ball in a manner to enable the players to observe the ball visibly leaving the hand of the player taking the throw, who shall also then be permitted to carry or dribble the ball before passing to another player, or to shoot, when permitted. The ball shall be in play immediately when it leaves the hand of the player taking the free throw.
- 11.4 A free throw is also awarded against the team which last touched the ball that went out of the side of the field of play (including the ball rebounding from the side of the field of play) except in the case of a defensive field player blocking a shot over the side of the field of play, in which case a free throw is given to the defensive team.

12. GOAL THROWS

- 12.1 A goal throw shall be awarded when the entire ball has passed fully over the goal line excluding between the goal posts and underneath the crossbar, having last been touched by any player other than the goalkeeper of the defending team.
- 12.2 The goal throw shall be taken according to VI.11.3 without undue delay by any player of the team from anywhere within the 2 metre area or where the ball is, if outside 2 metres. A goal throw not taken in accordance with this Rule shall be retaken.

13. CORNER THROWS

- 13.1 A corner throw shall be awarded when the entire ball has passed fully over the goal line excluding between the goal posts and underneath the crossbar, having last been touched by the goalkeeper of the defending team or when a defending player deliberately sends the ball over the goal line.
- 13.2 The corner throw shall be taken according to VI.11.3 without undue delay by a player of the attacking team from the 2 metre mark on the side nearest

to which the ball crossed the goal line. The throw does not need to be taken by the nearest player.

13.3 At the taking of a corner throw, no players of the attacking team shall be within the goal area.

13.4 A corner throw taken from the wrong position or before the players of the attacking team have left the goal area shall be retaken.

14. NEUTRAL THROWS

14.1 A neutral throw shall be awarded when:

- (a) at the start of a period, a referee is of the opinion that the ball has fallen in a position to the definite advantage of one team;
- (b) one or more players of opposing teams commit an ordinary foul at the same moment which makes it impossible for the referees to distinguish which player offended first;
- (c) both referees blow their whistles at the same moment to award ordinary fouls to the opposing teams;
- (d) neither team has possession of the ball and one or more players of opposing teams commit an exclusion foul at the same moment. The neutral throw shall be taken after the offending players have been excluded;
- (e) the ball strikes or lodges in an overhead obstruction.

14.2 At a neutral throw, a referee shall throw the ball into the field of play at approximately the same lateral position as the event occurred in such a manner as to allow the players of both teams to have an equal opportunity to reach the ball. A neutral throw awarded within the goal area shall be taken on the 2 metre line.

14.3 If at a neutral throw the referee is of the opinion that the ball has fallen in a position to the definite advantage of one team, the referee shall call for the ball and retake the throw.

15. PENALTY THROWS

15.1 A penalty throw shall be taken by any player of the team to which it is awarded from any point on the opponents' 5 metre line.

15.2 All players shall leave the 6 metre area and shall be at least three metres from the player taking the throw. On the 6 metre line, on each side of the player taking the throw, one player of the defending team shall have the first right to take position. The defending goalkeeper shall be positioned between the goal posts with no part of the goalkeeper's body beyond the goal line at water level. The referees can give one warning to the players or the goalkeeper to take up the correct position. If that person does not do so, the player or goalkeeper shall be excluded and shall re-enter in accordance with VI.9.3.

15.3 When the referee controlling the taking of the throw is satisfied that the players are in their correct positions, the referee shall signal for the throw to be taken, by whistle and by simultaneously lowering the arm from a vertical to a horizontal position.

- 15.4 The player taking the penalty throw shall have possession of the ball and shall immediately throw it with an uninterrupted movement directly at the goal. The player may take the throw by lifting the ball from the water or with the ball held in the raised hand and the ball may be taken backwards from the direction of the goal in preparation for the forward throw, provided that the continuity of movement shall not be interrupted before the ball leaves the thrower's hand.
- 15.5 If the ball rebounds from the goal post, crossbar or goalkeeper it remains in play and it shall not be necessary for another player to play or touch the ball before a goal can be scored.
- 15.6 If at precisely the same time as the referee awards a penalty throw the timekeeper whistles for the end of a period, all players except the player taking the throw and the defending goalkeeper shall leave the water before the penalty throw is taken. In this situation, the ball shall immediately be dead should it rebound into play from the goal post, crossbar or the goalkeeper.

16. PERSONAL FOULS, YELLOW AND RED CARDS

- 16.1 A personal foul shall be recorded against any player who commits an exclusion foul or penalty foul. The referee shall indicate the offending player's cap number to the secretary.
- 16.2 Upon receiving a third personal foul, a player shall be excluded from the remainder of the game with substitution after the earliest occurrence referred to in VI.9.3. If the third personal foul is a penalty foul, the entry of the substitute shall be immediate.
- 16.3 The referee, if necessary, must use Yellow and Red Cards to control the Team Officials and Substitute Players on the Team Bench as well as the players in the water. The use of Yellow and Red Cards applies to all World Aquatics Water Polo Competitions and will be administered as follows:
- 16.3.1 The issuing of a Yellow Card by the referee is an official warning to the Head Coach of the team.
- 16.3.2 The subsequent issuing of a Red Card by the referee is the signal that the Head Coach and/or other Team Official(s) and/or player(s) on the bench must leave pool area immediately. Should the actions of the Head Coach require it, the referee may issue a Red Card, without having issued a Yellow Card.
- 16.3.3 When the Head Coach is excluded from the game, another Team Official may replace the Head Coach, however without the privileges of the Head Coach. The Team Official is not allowed to stand and move away from the team bench but can ask for a timeout according to the Rules. During a timeout or after a goal, before the restart of the match, the Team Official may move freely along the side of the pool to the half distance line to instruct the team.
- 16.3.4 During the match, when a team member inside the water commits an act of misconduct, the referee must show a Red Card to the player accompanied by the appropriate sanction.
- 16.3.5 A referee may issue a Yellow Card, if, in the referee's opinion, a player persists in playing in an unsporting manner or engages in simulation (VI.8.4). The referee shall show a Yellow Card to the offending team and point to the offending player. Should the action continue, the referee will

show the player a Red Card visible to both the team and the official table as this is deemed to be misconduct (VI.9.13).

16.3.6 Team members committing an act of misconduct will be punished according to VI.9.13 and must leave the pool area immediately.

16.3.7 For any offense potentially leading to a player or team official being excluded from the remainder of a game, the Management Committee of the tournament shall assess all circumstances of the offense, in particular its gravity, and decide whether the player or team official shall be excluded from additional games in the tournament within 24 hours after the end of the game, with notification to the player, team official and team. The Management Committee shall also refer the matter to the Aquatics Integrity Unit if they consider that consequences beyond the tournament should be considered. For the sake of clarity, the Management Committee is entitled to review official video of any match of the tournament to decide whether the player or coach shall be excluded from other games in the tournament, regardless of whether or not the offense was sanctioned by the referee during the match.

If a player or team official is suspended from a specific match, the team shall have the number of players or team officials on the bench reduced accordingly; provided that there is at least one (1) team official on the bench.

If more than three members of the same team, including team officials, are excluded from a game, that team shall be disqualified from that game and the opposing team shall be awarded victory with the goal score of 5-0, unless the goal difference was higher than this at the time of the third exclusion from the match. In that case, the actual score shall be kept.

17. ACCIDENT, INJURY AND ILLNESS

- 17.1 A player shall only be allowed to leave the water, or sit or stand on the steps or side of the pool during play in the case of accident, injury, illness or with the permission of a referee. A player who has left the water legitimately may re-enter from the team's exclusion re-entry area at an appropriate stoppage, with the permission of a referee.
- 17.2 If a player is bleeding, the referee shall immediately order the player out of the water with the immediate entry of a substitute and the game shall continue without interruption. After the bleeding has stopped, the player is permitted to be a substitute in the ordinary course of the game.
- 17.3 If accident, injury or illness, other than bleeding, occurs, a referee, at the referee's discretion, may suspend the game for not more than three minutes, in which case the referee shall instruct the timekeeper as to when the stoppage period is to commence.
- 17.4 Should the game be stopped through accident, injury, illness, bleeding or other unforeseen reason, the team in possession of the ball at the time of the stoppage shall put the ball into play at the place of stoppage when the play is resumed.
- 17.5 Except in the circumstances of VI.17.2 (bleeding), the player shall not be allowed to take further part in the game if a substitute has entered.
- 17.6 In case of injury and the match is stopped by the referees, if the referees suspect that an incident of misconduct, including violence, may have occurred, the referees may review the video provided by the Video

Assistance Referee during the stoppage. If the referees determine that an incident did occur, the referees should sanction the incident according to the rules and the game should recommence from the time of the incident. Between the time of incident and time of stoppage, goals and personal fouls are nullified while yellow and red cards violent actions and misconducts will remain on the match protocol.

If no incident was identified, the game should recommence from the time of the stoppage.

Situations involving the VAR and/or VAR equipment must be managed by the referees according to the VAR protocol as explained in section IV Appendix 7.

18. WATER POLO FACILITIES

18.1 General Requirements

18.1.1 Water Polo Dimensions and Equipment as detailed in Field of Play diagram. See Water Polo Diagram 1

18.1.2 The overall Field of Play will be 30.60m x 20.00m for men and 25.60m x 20.00m for women.

The distance between the goal lines shall not be less than 20.00 metres and not more than 30.00 metres for games played by men. The distance between the goal lines shall not be less than 20.00 metres and not more than 25.00 metres for games played by women.

The anchor point at the edge of the Field of Play shall be placed 30cm behind the front of the goal line.

The width of the Field of Play shall be not less than 10 metres and not more than 20.00 metres.

Exception from this rule may be allowed on the discretion of the federation controlling the match.

18.1.3 The depth of the water shall be consistently not less than 1.80 metres.

18.1.4 The water temperature shall be 26° plus 1° minus 1° Centigrade (25°C-27°C).

18.1.5 The light intensity shall not be less than 600 lux.

18.1.6 Minimum Ceiling height is not required.

18.1.7 Lane Ropes

Each lane rope will have a minimum diameter of 0,06 metres and a maximum diameter of 0.12 metres.

Lane rope should be secured at each wall to anchor brackets recessed into the walls. If anchor placement is on pool deck, an extender, firm and non-elastic, should be in place. The installed lane rope should stay in the pool water. The anchor, including extender, shall not extend more than 10mm into the pool. The anchor shall not influence the length of the lane rope by more than ± 10 mm each end of rope. Anchors should be installed to withstand 20kN. The lane rope shall be equipped with a tension spring, absorbing

sudden high point loads and a wire withstanding a tensile force of 12kN.

18.1.8 Flying Substitution Area

An area for flying substitutions must be available on the lateral outer side of the field of play, on the side where the team benches are situated. The width of this area shall be not less than 0.50 metres.

The designated area for flying substitutions for each team will be between the goal line in front of the team bench and the centre of the field of play.

18.2 Water Polo facilities for Olympic Games and World Championships

18.2.1 General Requirements

Water Polo Dimensions and Equipment as detailed in Field of Play diagram for Olympic Games and World Championships. *See Water Polo Diagram, Appendix 2*

18.2.2 Field of play

The overall Field of Play will be 30.60m x 20.00m for men and 25.60m x 20.00m for women.

The distance between respective goal lines shall be 30.00 metres for games played by men and 25.00 metres for games played by women.

The anchor point at the edge of the Field of Play shall be placed 30cm behind the front of the goal line. The width of the Field of Play shall be 20.00 metres.

Exceptions from the requirements in II.16.3.2.2 are not allowed.

18.2.3 The depth of the water shall be consistently not less than 2.00 metres.

18.2.4 The water temperature shall be 26° plus 1° minus 1° Centigrade (25°C-27°C).

18.2.5 The light intensity shall not be less than 1500 lux.

18.2.6 In indoor swimming pools the minimum height of the Field of Play shall be not less than 7.00 meter.

18.2.7 Lane Ropes

Each lane rope will have a diameter of 0,10 metres.

Lane rope should be secured at each wall to anchor brackets recessed into the walls. If anchor placement is on pool deck, an extender, firm and non-elastic, should be in place. The installed lane rope should stay in the pool water. The anchor, including extender, shall not extend more than 10mm into the pool. The anchor shall not influence the length of the lane rope by more than ± 10mm each end of rope.

Anchors should be installed to withstand 20kN. The lane rope shall be equipped with a tension spring, absorbing sudden high point loads and a wire withstanding a tensile force of 12kN.

18.2.8 Flying Substitution Area

In indoor swimming pools the minimum height of the Field of Play shall be not less than 7.00 meter.

18.2.9 Salinity of the water

An area for flying substitutions must be available on the lateral outer side of the field of play, on the side where the team benches are situated. The width of this area shall be not less than 0.50 metres.

The designated area for flying substitutions for each team will be between the goal line in front of the team bench and the centre of the field of play.

18.3 Equipment for Water Polo facilities

18.3.1 Markings

Distinctive marks shall be provided on both sides of the field of play to denote the goal lines, lines 2.0 metres and 6.0 metres from that line and half the distance between the goal lines. These markings shall be clearly visible throughout the game.

The white marker shall be measured from the anchor point and will be 0.3 metres to line up with the front of the edge of the goal line. This shall be consistent at both ends of the field.

The 2 metre red marker shall be measured from the front end of the goal line extending into the field of play. This shall be consistent at both ends of the field of play.

The yellow marker shall then extend 4 metre from the 2 metre marker into the field of play. There will be a red marker placed 5 metre from the front end of the goal line. This shall be consistent at both ends of the field of play.

The middle section of the field of play will be green and should be 18 metre for the men's game and 13 metre for the women's game. There will be a white marker placed in the middle of the green area to denote the centre of the field.

The exclusion zones shall be placed in the two corners on the opposite side of the pool to the official table. They shall be 2 metre in length and shall extend along the goal line.

18.3.2 Referee platforms

Platforms must be provided on both sides of the field of play, which shall be 1 metre in width and 70 cm in height above the water level. These platforms enable the referees to have free way from end to end of the field of play. Sufficient space shall also be provided at the goal lines for the Goal Judges. The platforms must be colour coded to meet the specification as shown in the diagram of the field of play. *See Water Polo Diagram, Appendix 2*

18.3.3 Goals

The goal posts and crossbar must be of wood, metal or synthetic (plastic) with rectangular sections of 80,0 millimetres, square with the goal line and painted white.

The goal posts must be fixed, rigid and perpendicular at each end of the playing space, equal distances from the sides and at least 0.3 metre in front of the ends of the field of play or of any obstruction. Any standing or resting place for the goalkeeper other than the floor of the pool is not permitted.

The inner sides of the goal posts must be 3.0 metre apart.

The underside of the cross bar must be 0.9 metre above the water surface.

18.3.4 Re-entry area

The rectangular excluded players' re-entry area shall have the following dimensions: 2.0 metres by 1.08 metre.

18.3.5 Nets

Limp nets must be attached to the goal fixtures to enclose the entire goal space securely fastened to the goal posts and crossbar, allowing not less than 0.3m of clear space behind the goal line everywhere within the goal area.

18.3.6 Secretariat table

The game secretariat shall be placed at a table behind the referees and at the same height.

19. APPENDICIES

19.1 The following appendices are incorporated in and form part of these Rules:

Appendix 1 and 2 - Diagrams

Appendix 3 – Definitions

Appendix 4 – Field of Play and Equipment

Appendix 5– Officials

Appendix 6– Penalty Shoot Out

Appendix 7 – VAR Protocol

Appendix 8– Age Group Tournaments

Appendix 9– Tournaments Structure

APPENDIX 1 – DIAGRAMS

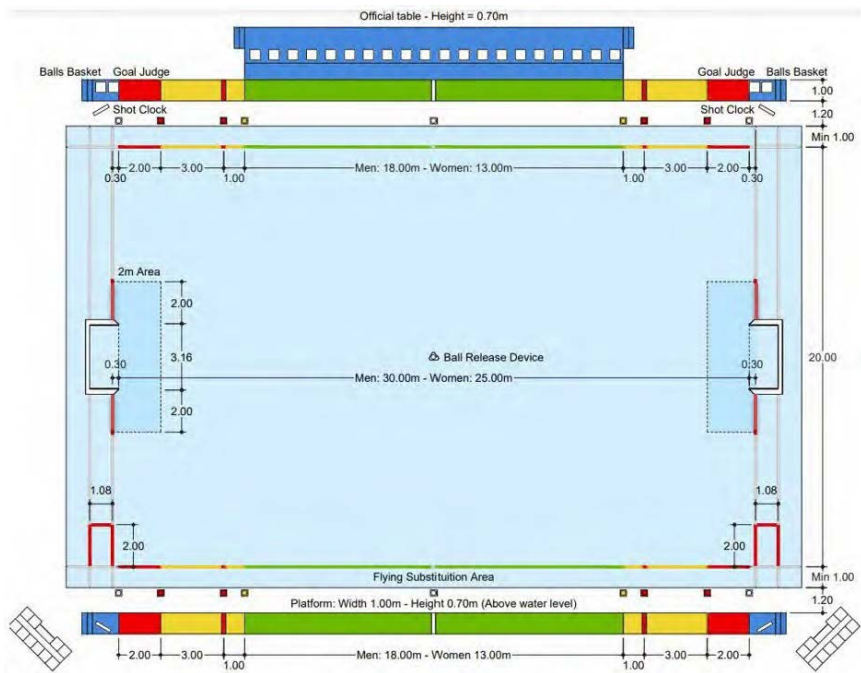

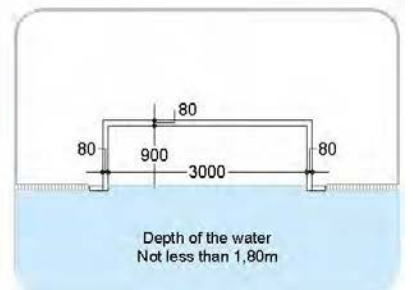
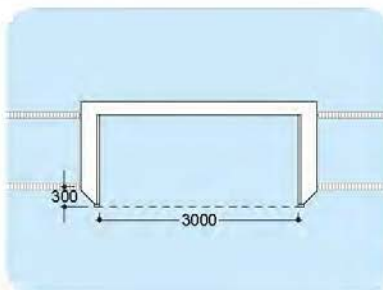
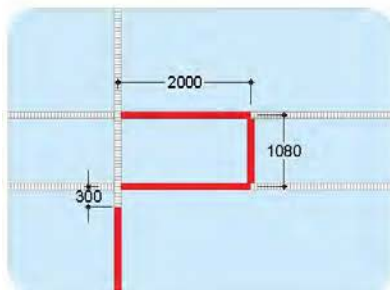
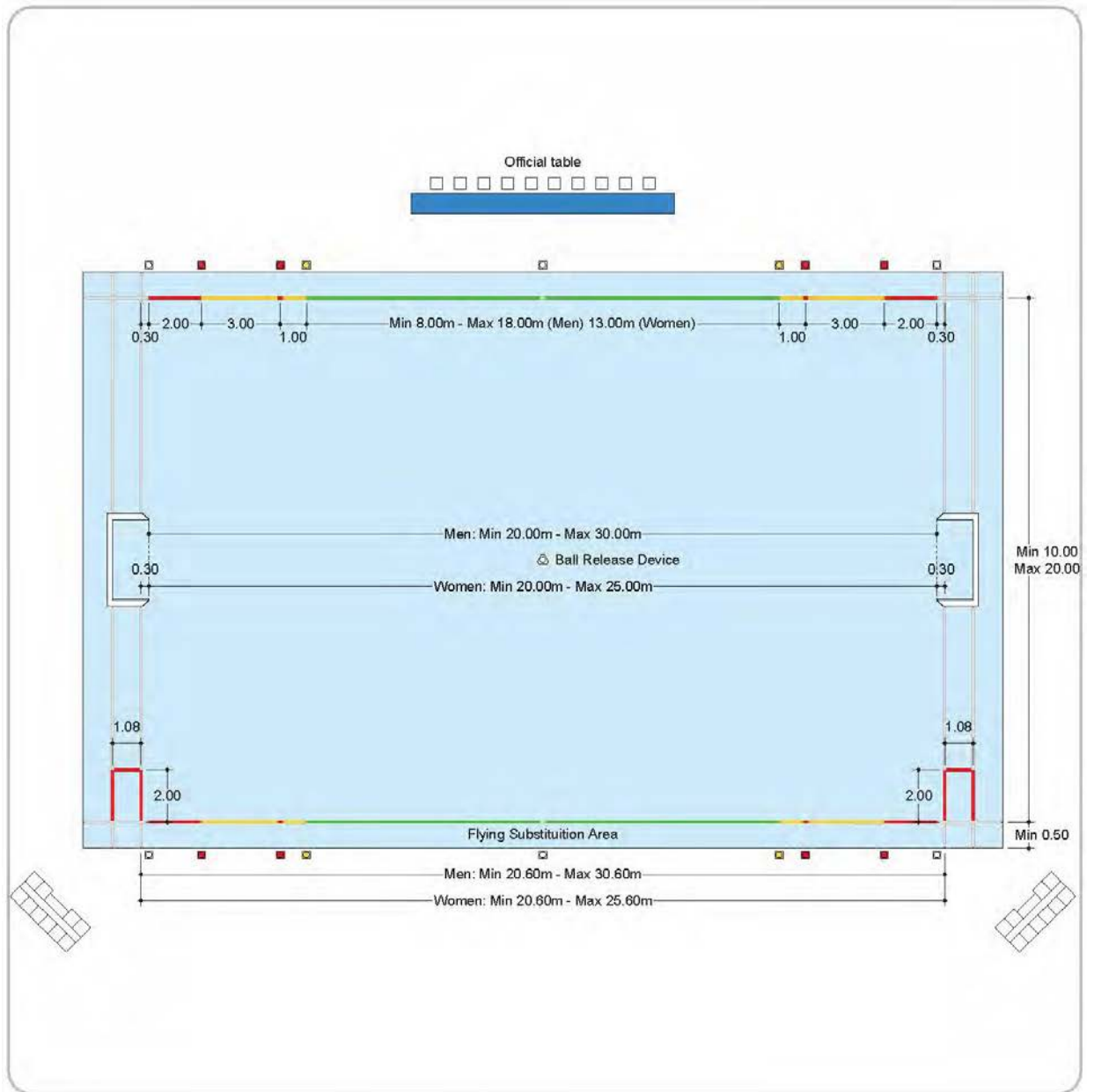

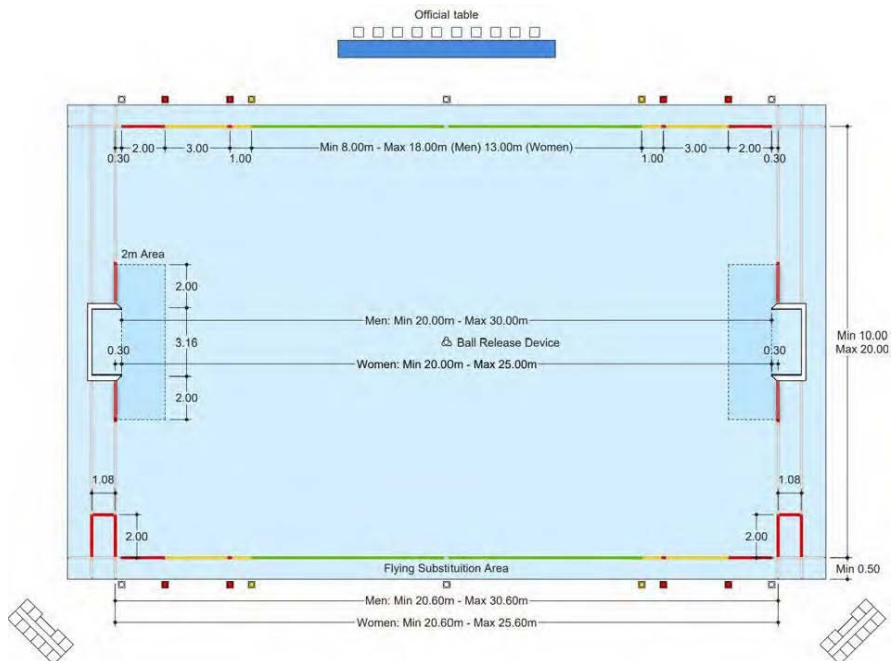

APPENDIX 2 - DIAGRAMS

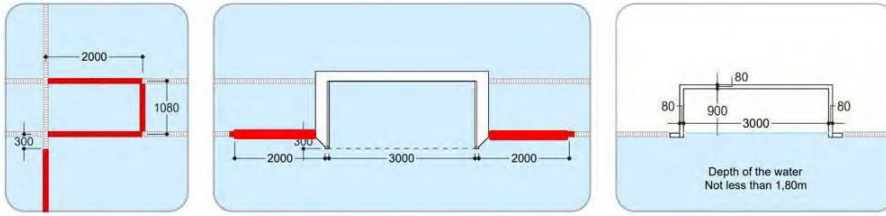

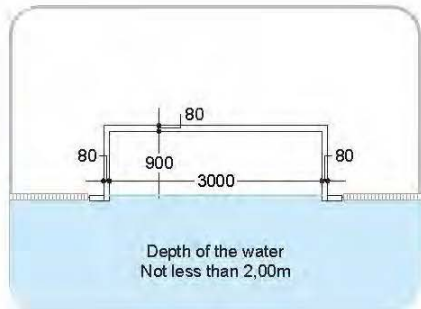
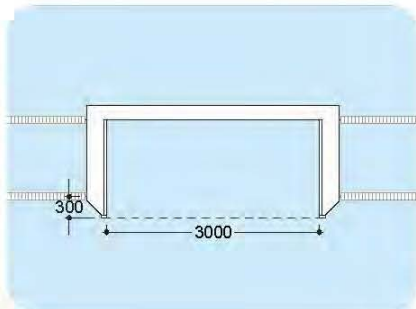
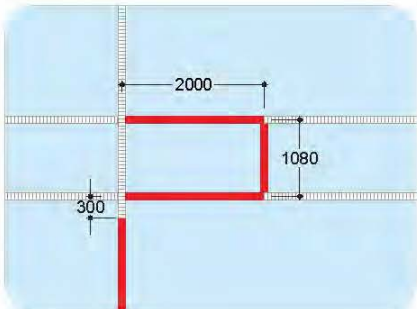
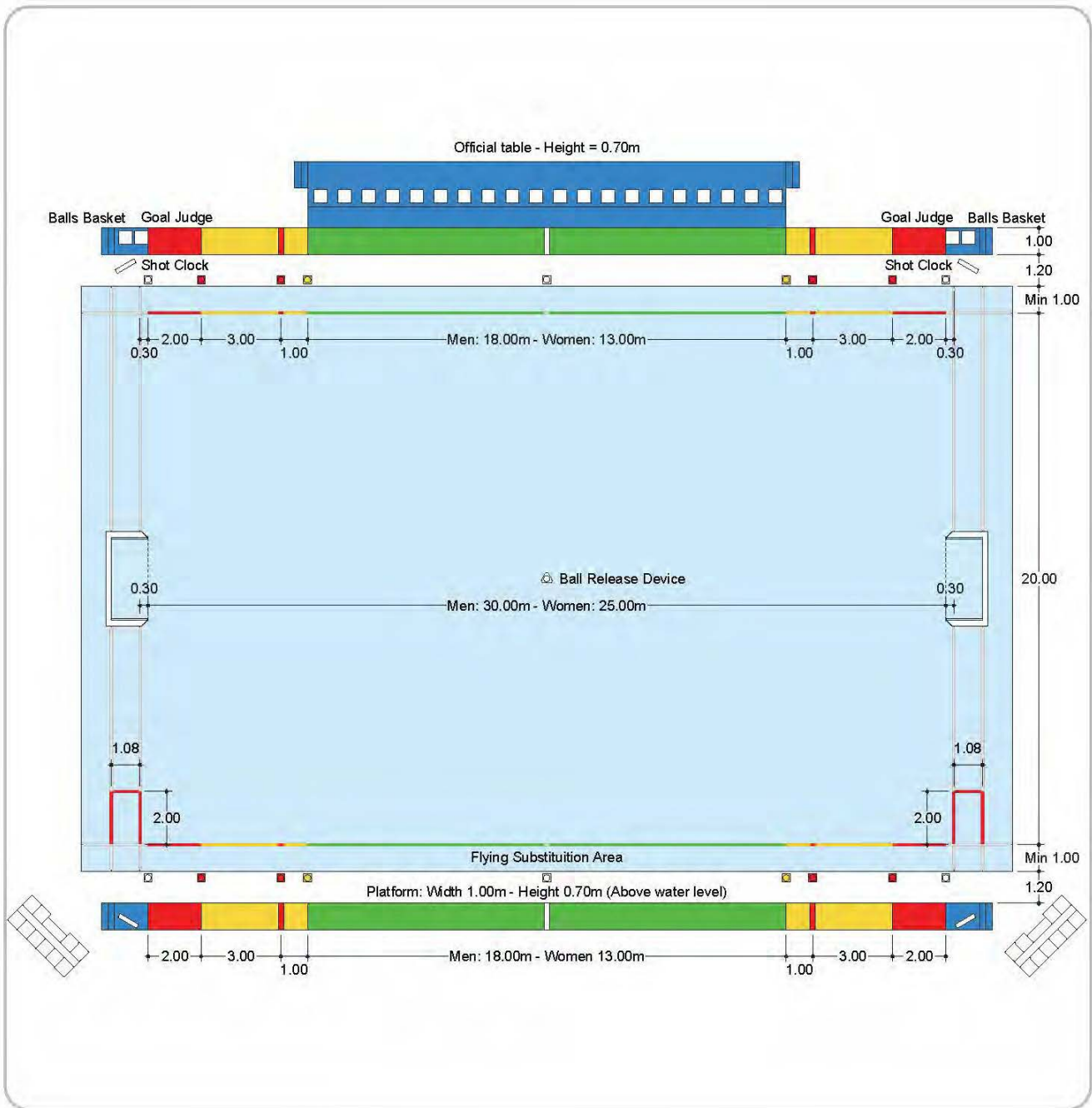

APPENDIX 3 – DEFINITIONS

1. FIELD OF PLAY & EQUIPMENT

- 1.1. **Field of Play:** The part of the water officially marked as the place for the action of a water polo game as described in Appendix 4.
- 1.2. **Official table:** The designated location where other necessary officials and authorized persons carry out their responsibilities during a game.
- 1.3. **Flying Substitution:** The ability of a team to exchange players during play from the flying substitution area.
- 1.4. **Flying Substitution Area:** The area designated by the Rules at the side of the Field of Play where flying substitutions may occur.
- 1.5. **Goal (definition A):** The result of the ball fully crossing the goal line past the front line of the goal posts and underneath the crossbar.
- 1.6. **Goal line:** the end of the field of play, formed by the front face of the goal post (VI 7.1)
- 1.7. **Goal area:** Is a rectangular box extending 2 metres from the lateral outsides of the goal posts to the 2 metre line opposite the goal line. In this area, attacking players must not enter without possession of the ball, unless they are behind the line of the ball.
- 1.8. **5 metre line:** Is the line, from where penalty throw should be taken.
- 1.9. **6 metre area:** is an area within 6 metres of the goal line where some fouls according the penalty rules, become a penalty foul.
- 1.10. **Half distance line:** Line which divides the length of the field of play into two equal halves at its midpoint.
- 1.11. **Goal:** The structure into which the ball must fully enter in order to score. (Appendix 4.2)

2. TEAMS AND SUBSTITUTES

- 2.1. **Team:** team of water polo players as described in Section VI
- 2.2. **Player:** an individual member of a water polo team.
- 2.3. **Goalkeeper:** individual member of a team, wearing a cap 1 or 13, whose main role is to prevent the ball from entering the goal. (Appendix 4.4.3)
- 2.4. **Substitute:** A player entering the field to replace a player already in the field of play or an excluded player.
- 2.5. **Reserve:** A team member who is not playing at the time.
- 2.6. **Designated lateral substitution area:** is “Area for Flying Substitutions”
- 2.7. **Exclusion Re-entry area:** Location from where a player or substitute returns to the field of play after an exclusion.
- 2.8. **Advantage:** The opportunity of an attacking player and/ or the attacking team to continue to play the ball in order to generate an opportunity to score. Referees must officiate such that the attacking team can maintain its advantage.

- 2.9. **Red Card:** Signal from the referee to indicate an exclusion from the remainder of the game, to a player, coach or any team official.
- 2.10. **Yellow Card:** Warning signal from the referee to the coach for inappropriate behaviour or insufficient bench discipline, or for repeated simulation and persistent foul play of a team.
- 2.11. **Offending player:** A player committing a foul according to the rules.

3. REFEREES AND TECHNICAL OFFICIALS

- 3.1. **Video assistant referee – VAR:** Video technology and assistant referee, which the referee may use to make a final decision after reviewing a situation in described situations in Appendix 5- VAR protocol.
- 3.2. **Referee:** An official responsible for conducting the game with designated functions fixed by the Rules.
- 3.3. **Possibility to play the ball:** When the player in possession of the ball is able to continue playing by putting the ball into action.
- 3.4. **Centre forward:** An attacking player whose primary position is near the opponent's 2 metre line and generally between the width of the goal posts.
- 3.5. **Centre back:** A defender whose primary responsibility is to mark the attacking centre forward. (See Centre Forward)
- 3.6. **Goal Judge or assistant referee:** An official seated on the goal line responsible for assisting the referee in determining if the ball has entered the goal or passed the goal line, including who last touched the ball as well as for throwing a new ball according to the referees' instructions.
- 3.7. **Start or restart:** The commencement of play at the beginning of a period, after a goal or after the referee has called for the ball and stopped play.

4. DURATION OF THE GAME

- 4.1. **Actual play:** Teams play four periods, each period consisting of eight minutes of actual playing time; a total of 32 minutes. Actual play starts at the beginning of each period, when a player touches the ball, stops on every stoppage indicated by the referee or shot clock and continues after every stoppage when the player puts the ball into play according to the Rules, shoots or passes the ball.
- 4.2. **Penalty Shoot-out:** The method of determining a definite result for a game should the scores be level at full time. The method is regulated by Annex D.
- 4.3. **Attacking Referee:** The referee who is giving primary attention to the attacking situation in front of the goal to the referee's right.
- 4.4. **Defensive Referee:** The referee who is controlling the attacking situation to the referee's left. This referee generally maintains a position no closer to the goal being attacked than that player of the attacking team furthest back from the goal.

5. TIMEOUTS

- 5.1. **Timeout:** A one-minute stoppage of play available to the attacking team at any time, except at the awarding of a penalty throw or during a VAR review. Each team is entitled to two timeouts per game.
- 5.2. **Illegal Timeout:** A requested timeout to which the team is not entitled.

5.3. **Possession:** Possession of the ball is when a player from one of the teams holding or swimming with the ball.

6. **METHOD OF SCORING**

6.1. **Visibly putting the ball into play:** means that the ball must leave the hand of the player with the ball. Throwing the ball from a player's left to right hand is considered putting the ball into play.

6.2. **Fake:** To simulate a shot.

6.3. **Swim up:** At the beginning of a period the ball is placed in the middle of the field of play and once the whistle is blown to signal the start of the game, teams sprint towards the middle of the pool to gain possession of the ball.

7. **ORDINARY FOULS**

7.1. **False Start:** To begin the start of play improperly, either before the signal from the referee or pushing off from or affecting the alignment of the goal.

7.2. **Foul:** A violation of a rule resulting in a stoppage of the game clock and the awarding of a free throw. There are two types of fouls:

- Physical fouls (physical contact of a player preventing an opposing player from continuing with movement)
- Technical fouls (against rules, e.g., false start or restart, to strike the ball with clenched fist, two hands, etc.)

7.3. **Ball under:** Ordinary foul called against a player for taking the ball under water when tackled by an opponent or with intent to hide a ball from an opponent.

7.4. **Simultaneous exclusion:** When two players from opposing teams are simultaneously excluded.

7.5. **Spirit of the Game:** Defining characteristic of the sport. Playing within the spirit means playing to win while respecting teammates, opponents and the game itself. It is defined by understanding the rules and playing with integrity and honesty in mind.

7.6. **Push-off:** To use the hand, arm, foot or another body part to push off an opponent to gain an advantage.

7.7. **Kicking:** A blow, strike or forceful thrust with the foot to an opponent's body or face, which is a personal foul.

7.8. **Simulation:** To pretend to be fouled.

7.9. **To drive:** An attacking move by a player who is facing an opponent and who attempts to aggressively swim by that player to a position of advantage closer to the goal.

7.10. **Driver:** A player who is driving towards the goal, usually starting from a stationary position facing an opponent attempting to aggressively swim by the opponent to a position of advantage closer to the goal.

7.11. **To tackle:** To hold, sink, pull back or impede a player who is holding the ball.

7.12. **Half distance line:** Line which divides the length of field of play into two equal halves at midpoint of course.

7.13. **Offensive Foul:** A foul committed by an attacking player resulting in a free throw awarded to the defending team.

7.14. **Holding the ball:** Lifting, carrying or touching the ball but not including dribbling

the ball.

8. EXCLUSION FOULS

- 8.1. **Improper Entry:** Entry of a player into the game during play not in accordance with the rules.
- 8.2. **Improper Re-entry:** Entry of a substitute into the game during play not in accordance with the rules.
- 8.3. **Exclusion Foul:** A foul where a player is excluded from taking part in the game for a period of time as prescribed in the Rules.
- 8.4. **Misconduct:** Any improper behaviour, including being disrespectful towards a referee or opponent, as well as showing disregard for an instruction from the referee.
- 8.5. **Violent action:** An action by a player intended to cause harm or to injure another player or official, regardless of whether contact is made.
- 8.6. **Aggressive foul play:** Behaviour that can lead to injuries of opponents. The intention of these kind of fouls is to destroy and completely stop the advantage or progress of the game or a player, or to provoke the opponent. It is dangerous play, without a clear intention to injure the opponent player, but typically is caused by emotions.
- 8.7. **Persistent foul play:** Unallowed fouls of defending players, which are stopping the attack. The intention of these fouls is not to injure an opponent, but to destroy the flow of the game, advantage and speed, as well as to intimidate the opponent.
- 8.8. **To Impede:** To obstruct movement with unallowed physical acts, like holding or blocking an opponent.
- 8.9. **To hold an opponent:** To use the hands, arms or legs to hold onto an opponent with the intention of restricting movement.
- 8.10. **To sink:** To push an opponent under the water.
- 8.11. **To Pull back:** To pull an opposing player.
- 8.12. **To interfere with a free throw, goal or penalty throw:** To disrupt or interfere with the taking of any of these throws.
- 8.13. **Disproportionate movements:** To make any movement with intent to kick or strike, even if the player fails to make contact.
- 8.14. **To strike:** Means “to hit”.
- 8.15. **Tactical foul:** Any foul by a defender with the objective to stop the flow of the game with intent to take away an advantage, especially the counterattack.
- 8.16. **Counterattack:** The transition by the attacking team that brings the ball quickly from one end of the field to the other in an attempt to score before the defensive team can get into position.

9. PENALTY FOULS

- 9.1. **Penalty Foul:** Any foul committed inside 6 metres preventing a probable goal (VI.10.2). Additionally, violent action (VI. 9.14), and delaying the game (VI. 10.10) may result in a penalty as well as VI. 10.9.
- 9.2. **Probable goal situation:** Situations in which the attacking player is facing the

goal and there is no defending player between the attacking player and the goalkeeper, and without a foul, a goal would most likely be scored. There are also probable goal situations when the goal is empty and the ball nearby, as well as examples described in the Manual.

- 9.3. **Bad pass:** A pass which cannot be reached by the attacker, regardless of whether or not the player has been fouled. There are no sanctions against the defending player in the case of a bad pass.
- 9.4. **Front position on a defender:** An offensive player establishing an advantageous position, that is, a position between a defending player and the opponent's goal.
- 9.5. **Delaying the game:** Intentionally preventing attacking players from proceeding with the action or any interference against the spirit of the game with the intention to prevent a probable goal.
- 9.6. **Illegal Player:** A player not entitled to participate in the game.

10. FREE THROWS

- 10.1. **Free Throw:** A method of putting the ball into play after an ordinary foul, an exclusion foul or a restart after a timeout, a goal, an injury including bleeding, the replacement of a cap, the referee calling for the ball, the ball leaving the side of the field of play or any other delay.
- 10.2. **To block a shot or pass:** To stop the ball's flight with hand, arm or body.
Shot: An attempt to score by purposely directing the ball towards the opponent's goal

11. GOAL THROWS

- 11.1. **Throw:** Any movement by hand releasing the ball, with intent to put the ball into play or pass or score.
- 11.2. **Free Throw:** The method of putting the ball into play following a foul or stoppage.
- 11.3. **Goal Throw:** The throw awarded to the defending team as described in VI. 12.
- 11.4. **Dribble the ball:** To swim with the ball or progress the ball by swimming. A player dribbling the ball is in possession of the ball but is not holding the ball.
- 11.5. **Pass the ball:** To throw the ball from one player to a teammate or to the area controlled by a teammate. To throw the ball towards a teammate (or to oneself) with the intention of keeping control of the ball (as opposed to the intention to score a goal).

12. CORNER THROWS

- 12.1. **Corner Throw:** Throw awarded to the attacking team on the defender's 2m line as described in VI. 13.2.
- 12.2. **Direct shot:** The ball may be shot directly at the goal:
 - A) following a free throw when the player, the ball and the foul are outside the 6 M line,
 - B) from a penalty throw,
 - C) from a corner throw. (Described in VI.7.2)

13. NEUTRAL THROWS

- 13.1. **Neutral Throw:** Method of putting the ball into play when neither team has

possession. The referee restarts play by throwing the ball into the pool between two opposing players, giving each an equal opportunity to recover the ball.

14. PENALTY THROWS

- 14.1. **Penalty Throw:** A free shot at the goal from the 5 metre line defended only by the goalkeeper. The defending goalkeeper shall be positioned on the goal line between the goal posts and may move forward after the referee gives the signal for the shot to be taken. Defending players may only enter the 6 metre area after the ball has left the hand of the shooting player.

15. PERSONAL FOULS

- 15.1. **Personal Foul:** Individualized foul recorded against a player, when the referee awards an exclusion or a penalty foul.

16. ADDENDUM WITH SOME OTHER OBSERVATIONS AND CLARIFICATIONS:

- 16.1. **Transition:** The phase of the game when a team changes from offense to defense or from defense to offense.
- 16.2. **Attacking player:** Player whose team has possession of the ball; the team controls the ball and has the opportunity to score a goal.
- 16.3. **Defending player:** Player whose team does not control, and does not have possession of, the ball; a player trying to defend the team's goal.

APPENDIX 4 - FIELD OF PLAY & EQUIPMENT

1 – FIELD OF PLAY

- 1.1 The promoting organisation shall be responsible for the correct measurements and markings of the field of play and shall provide all required fixtures and equipment.
- 1.2 The layout and markings of the field of play for a game officiated by two referees shall be in accordance with this diagram:

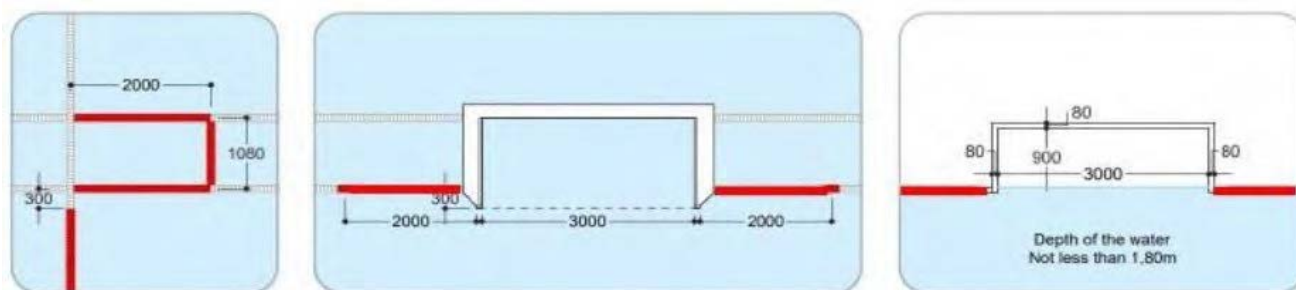

A Red Mark must be placed on the goal line, 2 metres from the outsides of the goal posts to mark the goal area.

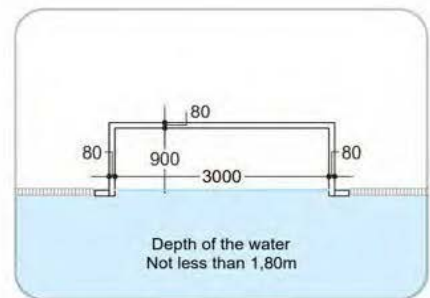
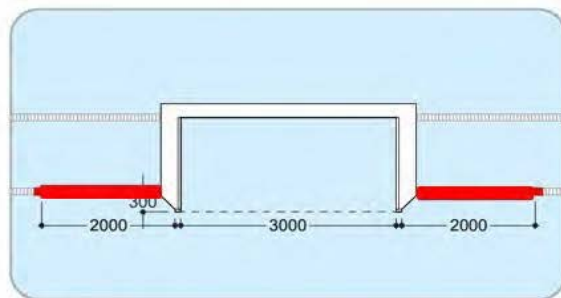
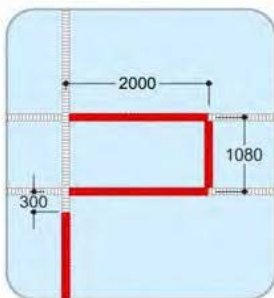
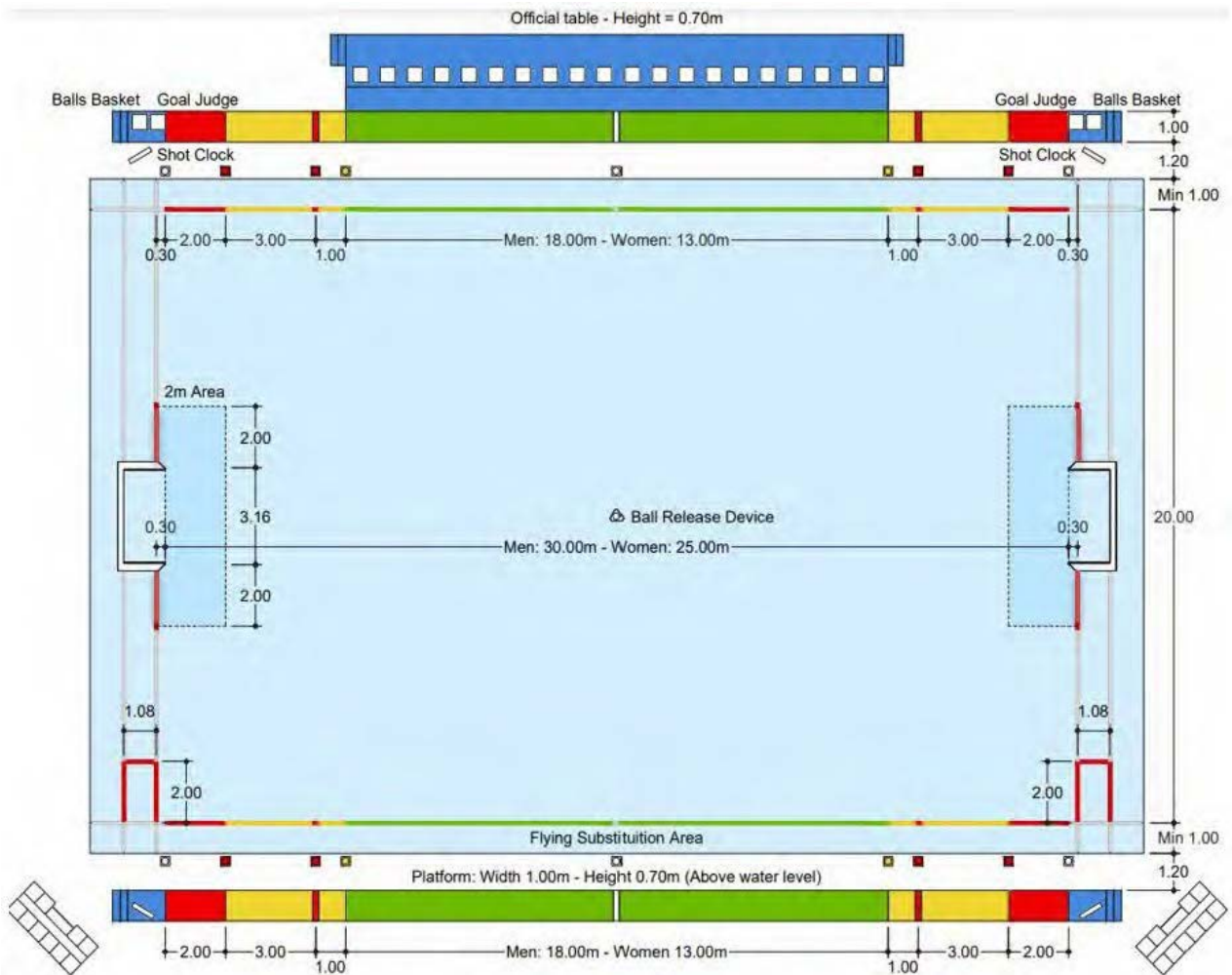

- 1.3 In a game officiated by one referee, the referee shall officiate on the same side as the official table, and the goal judges shall be situated on the opposite side.
- 1.4 For World Aquatics events, the dimensions of the field of play, water depth and temperature, and light intensity shall be as set forth in the Water Polo Facilities Rules.

- 1.5 Distinctive marks shall be provided on both sides of the field of play to denote the following:
- (a) white marks - goal line and half distance line
 - (b) red marks - 2 metres from goal lines
 - (c) yellow marks - 6 metres from goal lines
 - (d) a red marker shall be placed 5 metres from goal lines to indicate the point from which a penalty shot must be taken

The sides of the field of play from the goal line to the 2 metre line shall be marked in red; from the 2 metre line to the 6 metre line shall be marked in yellow and from the 6 metre line to the half distance line shall be marked in green.

- 1.6 A red mark shall be placed at each end of the field of play, 2 metres from the corner of the field of play on the side opposite to the official table, to denote the exclusion re-entry area.
- 1.7 Sufficient space shall be provided to enable the referees to have free movement from end to end of the field of play. Space shall also be provided at the goal lines for the goal judges.
- 1.8 The secretary shall be provided with separate white, blue, red and yellow flags, each measuring 0.35 metres x 0.20 metres.

2. GOALS

- 2.1 Two goal posts and a crossbar, rigidly constructed, rectangular with a dimension of 0.075 metres facing the field of play and painted white shall be located on the goal lines at each end, equal distances from the sides and not less than 0.30 metres in front of the ends of the field of play.
- 2.2 The inner sides of the goal posts shall be 3 metres apart. When the water is 1.50 metres or more in depth, the underside of the crossbar shall be 0.90 metres from the water surface. When the water is less than 1.50 metres in depth, the underside of the crossbar shall be 2.40 metres from the floor of the pool.
- 2.3 Limp nets shall be securely fastened to the goal posts and crossbar to enclose the entire goal area and shall be attached to the goal fixtures in such a manner as to allow not less than 0.30 metres clear space behind the goal line everywhere within the goal area.

3. BALL

- 3.1 The ball shall be round and shall have an air chamber with a self-closing valve. It shall be waterproof, without external strapping or any covering of grease or similar substance.
- 3.2 The weight of the ball shall be not less than 400 grammes and not more than 450 grammes.
- 3.3 For games played by men, the circumference of the ball shall be not less than 0.68 metres and not more than 0.71 metres, and its pressure shall be 7.5 to 8.5 pounds per square inch atmospheric. -
- 3.4 For games played by women, the circumference of the ball shall be not less than 0.65 metres and not more than 0.67 metres, and its pressure shall be 6.5 to 7.5 pounds per square inch atmospheric.

4. CAPS

- 4.1 Caps shall be of contrasting color, other than solid red, as approved by the referees, but also to contrast with the color of the ball. A team may be required by the referees to wear white or blue caps. The goalkeepers shall wear red caps with numbers and/or ear guards in the same colour as their team members' caps. Caps shall be fastened under the chin. If a player loses the cap during play, the player shall replace it at the next appropriate stoppage of the game when the player's team is in possession of the ball. Caps shall be worn throughout the entire game.
- 4.2 Caps shall be fitted with malleable ear protectors which shall be the same color as the team's caps except that the goalkeeper may have red protectors.
- 4.3 Caps shall be numbered on both sides with numbers 0.10 metres in height. The goalkeeper shall wear cap no. 1 and the other caps shall be numbered 2 to 13. A substitute goalkeeper shall wear a red cap numbered 13. A player shall not be allowed to change cap number during the game except with the permission of a referee and with notification to the secretary.
- 4.4 For Olympic Games only: Caps shall be numbered on both sides with numbers 0.10 metres in height. The goalkeeper shall wear cap no. 1 and the other caps shall be numbered 2 to 11. A player shall not be allowed to change cap number during the game except with the permission of a referee and with notification to the secretary.
- 4.5 For international games, the caps shall display on the front the international three letter country code and may display the national flag. The country code shall be 0.04 metres in height.

5. VISIBLE CLOCKS

- 5.1 Any visible clock shall show the time in a descending manner.

APPENDIX 5 - OFFICIALS

1. OFFICIALS FOR WORLD AQUATICS EVENTS

- 1.1 For World Aquatics events the officials shall consist of two referees, two assistant referees, timekeepers and secretaries and a video assistant referee, each with the following powers and duties. These officials shall also be provided wherever possible for other events, except that in a game refereed by two referees and no assistant referees, the referees shall assume the duties (but without making the specified signals) allocated to the assistant referees.

Depending on the degree of importance, games can be controlled by teams of four to nine officials, as follows:

(a) Referees and assistant referees: Two referees and two assistant referees; or two referees and no assistant referees; or one referee and two assistant referees.

(b) Timekeepers and secretaries: With one timekeeper and one secretary: The timekeeper shall record the periods of continuous possession of the ball by each team, in accordance with VI.8.14. The secretary shall record the exact periods of actual play, timeouts and the intervals between periods, maintain the record of the game as set out in VI.10.1 and shall also record the respective periods of exclusion of players ordered from the water in accordance with the Rules.

With two timekeepers and one secretary: Timekeeper No. 1 shall record the exact periods of actual play, timeouts and the intervals between periods. Timekeeper No. 2 shall record the periods of continuous possession of the

ball by each team, in accordance with VI.8.14. The secretary shall maintain the record of the game and perform all other duties as set out in the Water Polo Rules.

With two timekeepers and two secretaries: Timekeeper No. 1 shall record the exact periods of actual play, timeouts and the intervals between periods. Timekeeper No. 2 shall record the periods of continuous possession of the ball by each team, in accordance with VI.8.14. Secretary No. 1 shall maintain the record of the game. Secretary No. 2 shall carry out the duties relating to the improper re-entry of excluded players, improper entry of substitutes, exclusion of players and the third personal foul.

(c) Video assistant referee: shall assist the two referees as called for by the Rules.

2. REFEREES

- 2.1 The use of audio equipment by the referees of the match. During the match, both referees shall have an audio headset for communication between themselves. The delegate and the VAR assistant referees will also have one, but only to receive information for the official table and to ensure clarity.
- 2.2 All decisions of the referees on questions of fact shall be final and their interpretation of the Rules shall be obeyed throughout the game. The referees shall not make any presumption as to the facts of any situation during the game but shall interpret what they observe to the best of their ability.
- 2.3 The referees shall whistle to start and restart the game and to declare goals, goal throws, corner throws (whether signalled by the assistant referee or not), neutral throws and infringements of the Rules. A referee may alter a decision provided it is done before the ball is put back into play.
- 2.4 The referees shall have the power to order any player from the water in accordance with the appropriate Rule and to abandon the game should a player refuse to leave the water when so ordered.

3. ASSISTANT REFEREES

- 3.1 The assistant referees shall be situated on the same side as the official table, each on the goal line at the end of the field of play.
- 3.2 The duties of the assistant referees shall be:
 - (a) to signal by raising one arm vertically when the players are correctly positioned on their respective goal lines at the start of a period;
 - (b) to signal by raising both arms vertically for an improper start or restart;
 - (c) to signal by pointing with the arm in the direction of the attack for a goal throw;

- (d) to signal by pointing with the arm in the direction of the attack for a corner throw;
- (e) to signal by raising and crossing both arms for a goal;
- (f) to signal by raising both arms vertically for an improper re-entry of an excluded player or improper entry of a substitute.

3.3 Each assistant referee shall be provided with a supply of balls and when the original ball has gone outside the field of play, the assistant referee shall immediately throw a new ball to the goalkeeper (for a goal throw), to the nearest player of the attacking team (for a corner throw), or as otherwise directed by the referee.

4. **TIMEKEEPERS**

4.1 The duties of the timekeepers shall be:

- (a) to record the exact periods of actual play, timeouts and the intervals between the periods;
- (b) to record the periods of continuous possession of the ball by each team;
- (c) to record the exclusion times of players ordered from the water in accordance with the Rules, together with the re-entry times of such players or their substitutes;
- (d) to audibly announce the start of the last minute of the game;
- (e) to signal by whistle after 45 seconds and at the end of each timeout.

4.2 A timekeeper shall signal by whistle (or by any other means provided it is distinctive, acoustically efficient and readily understood), the end of each period independently of the referees and the signal shall take immediate effect except:

- (a) in the case of the simultaneous award by a referee of a penalty throw, in which event the penalty throw shall be taken in accordance with the Rules;
- (b) if the ball is in flight and crosses the goal line, in which event any resulting goal shall be allowed.

5. **SECRETARIES**

5.1 The duties of the secretaries shall be:

- (a) to maintain the record of the game, including the players, the score, timeouts, exclusion fouls, penalty fouls, and personal fouls awarded against each player;
- (b) to control the periods of exclusion of players and to signal the expiration of the period of exclusion by raising the appropriate flag or by another approved method of signalling; except that a referee shall signal the re-entry of an excluded player or a substitute when that player's team has retaken

possession of the ball. After 4 minutes, the secretary should signal the re-entry of a substitute for a player who has been excluded for violent action by raising the yellow flag along with the appropriate coloured flag or by another approved method of signalling;

(c) to signal with the red flag and by whistle, or by another approved method of signalling, for any improper re-entry of an excluded player or improper entry of a substitute (including after a signal by an assistant referee to indicate an improper re-entry or entry), which signal shall stop play immediately;

(d) to signal, without delay, the award of a third personal foul against any player as follows:

- (i) with the red flag, or by another approved method of signalling, if the third personal foul is an exclusion foul;
- (ii) with the red flag and a whistle, or by another approved method of signalling, if the third personal foul is a penalty foul.

6. VIDEO ASSISTANT REFEREE

6.1 The duties of the Video Assistant referee shall be:

(a) to alert and assist the match referee(s) in doubtful “goal / no goal” situations or in case of violent action situations by providing the video footage at the appropriate moment.

(b) if necessary, in other situations, to provide assistance to the referees with video footage;

(c) to show the match referee(s) re-plays of other incidents, when requested.

7. INSTRUCTIONS FOR THE USE OF TWO REFEREES

7.1 The referees are in absolute control of the game and shall have equal powers to declare fouls and penalties. Differences of opinion of the referees shall not serve as a basis for protest or appeal.







7.2 The committee or organisation appointing the referees shall have power to designate the side of the pool from which each referee shall officiate. Referees shall change sides of the pool before the start of any period when the teams do not change ends.







7.3 At the start of the game and of each period, the referees will position themselves on the respective six (6) metre line. The starting signal shall be given by the referee on the same side as the official table.







7.4 After a goal, the signal to restart shall be given by the referee who was controlling the attacking situation when the goal was scored. Before restarting, the referees shall ensure that any substitutions have been completed.







- 7.5 Each referee shall have the power to declare fouls in any part of the field of play but each referee shall give primary attention to the offensive situation attacking the goal to the referee's right. The referee not controlling the attacking situation (the defensive referee) generally shall maintain a position no closer to the goal being attacked than that player of the attacking team furthest back from the goal.
- 7.6 When awarding a free throw, goal throw or corner throw, the referee making the decision shall blow the whistle and both referees shall indicate the direction of the attack, to enable players in different parts of the pool to see quickly which team has been awarded the throw. Referees shall use the signals set out in the following C.8 to indicate the nature of the fouls which they are penalising.
- 7.7 The signal for a penalty throw to be taken shall be made by the attacking referee, except that a player who wishes to take the throw with the left hand may request the defensive referee to make the signal.
- 7.8 When simultaneous awards are made for ordinary fouls but for opposing teams, the award shall be a neutral throw by the attacking referee.
- 7.9 When simultaneous awards are made by both referees and one is for an ordinary foul and the other is for an exclusion foul or penalty foul, the exclusion foul or penalty foul award shall be applied.
- 7.10 When players of both teams commit an exclusion foul simultaneously during play, the referees shall call the ball from the water and make sure both teams and the secretaries know who is excluded. The possession clock is not reset and play is restarted with a free throw to the team which had possession of the ball. If neither team had possession when the simultaneous exclusions were called, the possession clock is reset to 30 seconds and play shall be restarted with a neutral throw.
- 7.11 In the event of simultaneous awards of penalty throws to both teams, the first throw shall be taken by the team last in possession of the ball. After the second penalty throw has been taken, the game will restart with the team which had possession of the ball receiving a free throw on or behind the half distance line. The possession clock is reset to 30 seconds.

8. SIGNALS TO BE USED BY OFFICIALS

<p>A. The referee lowers the arm from a vertical position to signal (i) the start of the period (ii) to restart after a goal (iii) the taking of a penalty throw.</p>	
<p>B. To point with one arm in the direction of the attack and, if necessary, to use the other arm to indicate the place where the ball is to be put into play at a free throw, goal throw or corner throw.</p>	
<p>C. To signal a neutral throw. The referee points to the place where the neutral throw has been awarded, points both thumbs up and calls for the ball.</p>	
<p>D. To signal the exclusion of a player. The referee points to the player and then moves the arm quickly towards the boundary of the field of play. The referee then signals the excluded player's cap number so that it is visible to the field of play and the table.</p>	
<p>E. To signal the simultaneous exclusion of two players. The referee points with both hands to the two players, signals their exclusion in accordance with Fig. D, and then immediately signals the players' cap numbers.</p>	
<p>F. To signal the exclusion of a player for misconduct. The referee signals exclusion in accordance with Fig. D (or Fig. E if appropriate) and then rotates the hands round one another in such a way that is visible to both the field of play and the table in addition to issuing the player with a red card. The referee then signals the excluded player's cap number to the table.</p>	

<p>G. To signal the exclusion of a player with substitution after four (4) minutes. The referee signals exclusion in accordance with Fig D (or Fig. E if appropriate) and then crosses the arms in such a way that is visible to both the field of play and the table in addition to issuing the player with a red card. The referee then signals the excluded player's cap number to the table.</p>	
<p>H. To signal the award of a penalty throw. The referee raises an arm with five fingers in the air. The referee then signals the offending player's cap number to the table.</p>	
<p>I. To signal that a goal has been scored. The referee signals by whistle and by immediately pointing to the centre of the field of play.</p>	
<p>J. To indicate the exclusion foul of holding an opponent. The referee makes a motion holding the wrist of one hand with the other hand.</p>	
<p>K. To indicate the exclusion foul of sinking an opponent. The referee makes a downward motion with both hands starting from a horizontal position.</p>	
<p>L. To indicate the exclusion foul of pulling back an opponent. The referee makes a pulling motion with both hands vertically extended and pulling towards his body.</p>	

<p>M. To indicate the exclusion foul of kicking an opponent. The referee makes a kicking movement.</p>	
<p>N. To indicate the exclusion foul of striking an opponent. The referee makes a striking motion with a closed fist starting from a horizontal position.</p>	
<p>O. To indicate the ordinary foul of pushing or pushing off from an opponent. The referee makes a pushing motion away from the body starting from a horizontal position.</p>	
<p>P. To indicate the exclusion foul of impeding an opponent. The referee makes a crossing motion with one hand horizontally crossing the other.</p>	
<p>Q. To indicate the ordinary foul of taking the ball under the water. The referee makes a downward motion with a hand starting from a horizontal position.</p>	
<p>R. To indicate the ordinary foul of standing on the bottom of the pool. The referee raises and lowers one foot.</p>	
<p>S. To indicate the ordinary foul of undue delay in the taking of a free throw, goal throw or corner throw. The referee raises a hand once or twice with the palm turned upwards.</p>	

<p>T. To indicate the ordinary foul of a violation of the two-metre rule. The referee indicates the number 2 by raising the fore and middle fingers in the air with the arm vertically extended.</p>	
<p>U. To indicate the ordinary foul of expiry of possession time. The referee moves a hand in a circular motion two or three times.</p>	
<p>V. To indicate that a direct shot from outside the 6 m. area is permitted.</p>	
<p>W. To indicate a change of possession</p>	
<p>W. By an assistant referee to signal for the start of a period</p>	
<p>X. By an assistant referee to signal an improper start, restart or improper re-entry of an excluded player or substitute.</p>	
<p>Y. By an assistant referee to signal a goal throw or corner throw.</p>	

Z. By an assistant referee to signal a goal.



To indicate a player's cap number. To enable the referee to communicate better with the players and the secretary, signals are made using both

hands if appropriate where the number exceeds five. One hand shows five fingers with the other hand showing additional fingers to make up the sum of the player's number. For the number ten, a clenched fist is shown. If the number exceeds ten, one hand is shown as a clenched fist with the other hand showing additional fingers to make up the sum of the player's number.

APPENDIX 6 - PENALTY SHOOT OUT

1. Procedure

- 1.1 If a penalty shoot out is necessary, the following procedure shall be followed.
- 1.2 If it involves the two teams having just completed a game, the shoot out will begin immediately and the same referees will be used.
- 1.3 The respective coaches of the teams will be requested to nominate five players and a goalkeeper who will participate in the penalty shoot out; the goalkeeper may be one of the shooters; the goalkeeper may be changed at any time, provided the substitute was listed in the team list in that game, however the substitute cannot be substituted as one of the shooters.
- 1.4 The five players nominated will be required to be listed in order and that order will determine the sequence in which those players will shoot at their opponent's goal; the sequence cannot be changed.
- 1.5 No players excluded for the game are eligible to be listed among those players to shoot or substitute as goalkeeper.
- 1.6 if the goalkeeper is excluded during the penalty shoot out, a player from the nominated five players may substitute for the goalkeeper but without the privileges of the goalkeeper; following the taking of the penalty shot, the player may be substituted by another player or alternate goalkeeper. If a field player is excluded during the penalty shoot out, the player's position is removed from the list of the five players participating in the penalty shoot out, and a substitute player is placed in the last position on the list.
- 1.7 Shots will be taken alternately at each end of the field of play, unless conditions at one end of the field of play advantage and/or disadvantage a team, in which case all shots may be taken at the same end. The players taking the shots will remain in the water in front of their bench, the goalkeepers will change ends, and all players not involved must sit on their team bench.
- 1.8 In the case of a goalkeeper substitution, the goalkeeper swims from the goal to the side of the jury table and remains near the centre of the field in the water, outside the field of play. The substitute goalkeeper enters the field of play. For any further substitutions, the goalkeeper and substitute goalkeeper switch positions.
- 1.9 The team to shoot first will be determined by toss of a coin.
- 1.10 Should teams still be tied following the completion of the initial five penalty

shots, the same five players shall then take alternate shots until one team misses and the other(s) score.

2. Starting Position

1. 5 shooters of each team inside the FOP between the 6 metre and half distance line,
2. One goalkeeper for each team in the goal in front of their opponent's bench.
3. No assistant referees are required.
4. Depending on the shooter, one referee will manage the shooter and the goal keeper and when both are in position, the referee shall blow the whistle and the other referee shall assist on the goal line.

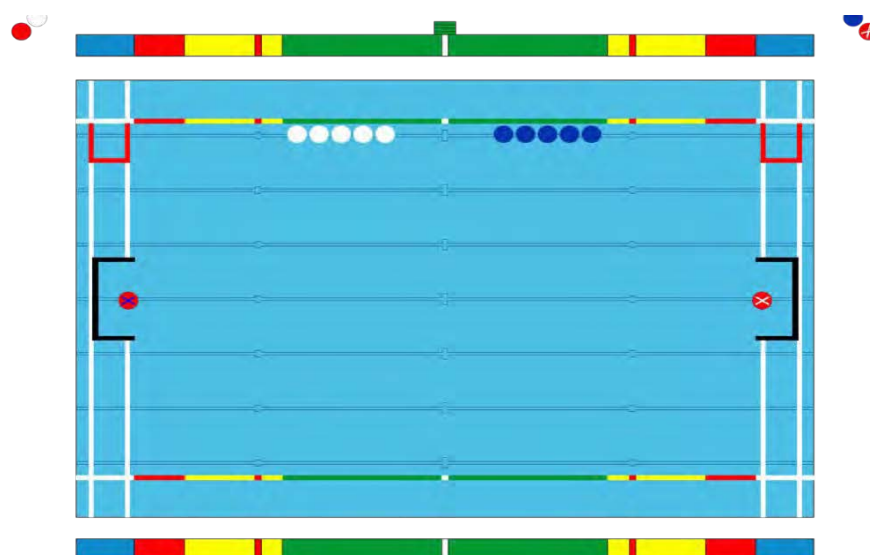

3. Substituting the goalkeeper, during the PSO, is allowed according to the following procedure (see below the blue arrows):

1. The substitute goalkeeper has to enter the lateral substitution area from behind the extended goal line, to swim to the 2 metre line in front of the opponent's team bench.
2. The substitute goalkeeper enters the field of play and takes the position of the first goalkeeper.
3. The goalkeeper who is substituted must swim to the centre and exit the the field of play in front of the jury table and wait (to be re-substituted or until the end of the PSO).

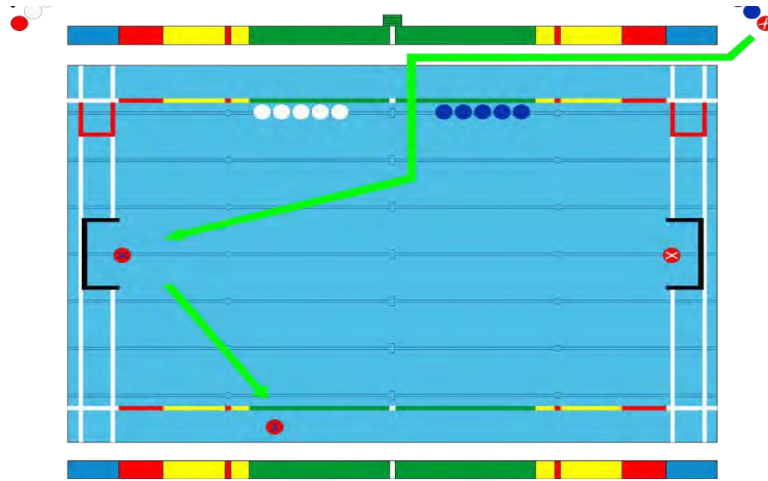

4. **Re-substituting the goalkeeper.** It is possible to substitute the goalkeeper again during a PSO by swimming according to the blue arrows below:

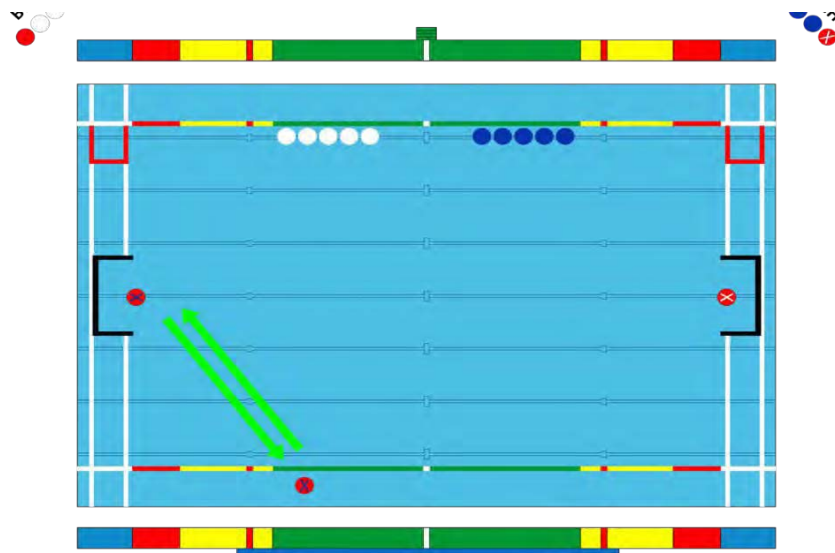

5. **Summary:**

During the PSO:

1. The delegate controls the correct order of the shooters and the score.
2. The referees manage the teams.
3. No warming up is allowed during the PSO.
4. All players not involved in the PSO must sit on the bench together with the team officials.
5. During the PSO, none of the players is allowed to hang onto the line.
6. A goalkeeper can substitute by swimming, as indicated in the PSO protocol, to the goal.
7. The substituted goalkeeper will stay in the water, at the centre

outside the field of play, in front of the jury table.

8. Every subsequent substitution of the goalkeeper occurs in a similar manner.

6. For Tie Breaking

If a penalty shoot out is necessary to break a tie, the following procedure shall be followed:

- (a) If it involves the two teams having just completed a game, the shoot out will begin immediately and the same referees will be used.
- (b) Otherwise, the shoot out will occur 30 minutes following the completion of the final game of that round, or at the first practical opportunity. The referees involved in the most recent game of that round will be used, provided they are neutral.
- (c) If three or more teams are involved, each team will shoot five penalty shots against each of the other teams, alternating at each shot. The order of the first shot will be determined by draw.

All other procedures shall occur in accordance with the procedures set out in this Appendix 6.

7. Procedure for Penalty Shoot Out

If a penalty shootout (PSO) has to determine the outcome of a game (according to WP 12.3), the following procedure and protocols must be followed:

Target

Make the PSO process as fast as possible, complying with the Rules.

Officials Involved

- 1.12. **Delegates:** priority to check if the shooters can participate in PSO (no player with three (3) personal fouls or has received a red card or can no longer participate due to injury) and to control the same order of shooters (five (5) shooters) after the first round of penalties has taken place.
- 1.13. **Referees:** priority to control the field of play, benches, position of goalkeepers and shooters in the field of play.
- 1.14. **Video Assistant Referee:** goal no goal assistant if needed.

Procedure

1. Immediately after the end of the 4th period, there is a **3-minutes break** during which the following actions need to be completed:
 - a. the players leave the water and sit on their respective team benches, except for five (5) shooters of each team who will remain in the water in their respective team's half of the field of play, and the goalkeepers.
 - b. the goalkeepers change ends and position themselves in the goal in the opposite team's half of the field.
 - c. the referee who last officiated on the side of the team benches will call the team captains and with a coin toss will determine which team will shoot the first penalty.
 - d. Goal Judges are not involved in PSO.

2. After the end of the 3-minute break, the PSO will start immediately. If a team fails to be ready in-time, the team's coach shall be warned by issuing a **yellow card**. If the coach has already been warned by a yellow card, a red card shall be issued for delaying the PSO. If the head coach has already been excluded, any other bench official can only receive a red card for delaying the PSO.

3. When shooting alternately at each goal, only **one referee** will control each penalty. Referees will position themselves on the 5-meter lines at opposite ends of the field such that right-handed shooters can easily observe the referee's signals. A referee will only walk to the other end of the field if a left-handed shooter is ready to take the next penalty.

4. Multiple balls can be used for the PSO. The ball shall not be thrown from one end of the field to the other. Each side will use their own set of balls.

5. The order of shooters for each team will be determined as they shoot the first round of five (5) penalties. (No list of shooters needs to be written down before the start of the PSO.) The secretary shall record the numbers of the players who take the penalties and, together with the delegate, shall check if the shooters are eligible to participate in the PSO (no three (3) personal fouls or excluded with red card, or because of injury). If the teams are tied after the ~~initial~~ first round of five (5) penalty shots, the same players shall continue in the same order as established after the first round of penalty takers.

APPENDIX 7 - VAR PROTOCOL

“One protocol – used by all”

The purpose of World Aquatics VAR protocol is to provide the integrity, transparency for all Water Polo games and eliminate the failure of the human factor with the assistance of modern technology.

1. PRINCIPLES

The final decision is always made by the referees. The referee can change his/her original decision based on facts from the VAR review.

Only the referee of the match can request a review. The Video Assistant Referee and the delegate can only alert the referee to conduct a review.

The referee will stop the match at an appropriate moment, as soon as possible.

During a VAR review the referee should remain visible throughout the process.

Accuracy is more important than speed, therefore there is no time pressure to review the decision quickly.

A match is not invalidated because of malfunction(s) of the VAR technology, wrong decision(s) involving the VAR, decision(s) not to review an incident or review(s) of a non-reviewable situation.

1.1 Appropriate moment definition

- Neither team has possession of the ball
- Interval time
- Corner throw
- Team in possession of the ball has no clear advantage
- At the latest, the review should be done after the first attack following a doubtful “GOAL / NO GOAL” situation.

2. SITUATIONS FOR REVIEW DURING THE MATCH

The use of VAR is limited to the following categories of decisions:

- Goal/ No goal.
- Goal scored at shot clock expiration or at the end of a period.
- Jury table errors and/or failures of the electronic system including time out buttons.
- When there is a shot taken at the end of a period and there is an excluded player.
- Review of a violent action situation.
- Interference with the taking of a penalty throw.

2.1 Goal/No goal situation

If the referee or VAR official has doubt about a goal/no goal situation, the referee should review the situation to assess if the ball fully crossed the goal line.

E.2.1.1 If a goal has been awarded:

- One of the referees of the match shall signal that the goal must be reviewed.
- One of the referees takes the ball out of the water.
- One referee, closest to the VAR monitor, reviews the situation and takes the decision to allow or disallow the goal.
- If the goal is cancelled, the former defending goalkeeper will restart the game with a free throw. The players shall be allowed to take any position in the field of play as after a timeout.
- If the goal is allowed, the game restarts according to VI.6.4

2.1.2 If a goal was not awarded:

The Referees of the match must find an appropriate moment, as quickly as possible after the situation, to review it. It should happen soon after the end of the first attack following the doubtful “GOAL / NO GOAL” situation.

After reviewing if a goal is awarded:

the game restarts according to VI.6.4 the time is reset to the moment when the goal was scored, all goals and personal fouls are nullified but all yellow and red cards, acts of violence and misconduct will remain on the match protocol.

After reviewing if a goal is not awarded:

the game restarts with a free throw taken by the team which last had possession, the time is not reset, and the players are allowed to take any position in the field of play as after a time out.

2.2 A Goal scored at the expiration of the shot clock or at the end of a period.

When a goal was scored very close to shot clock time expiration, or during the time expiration at the end of a period, the referee should check if the ball left the hand of the attacker before the time expired.

The video review will only be done immediately after a goal was scored from this shot.

If the result of the shot was a corner throw or rebound, no video review shall be done.

If this situation happens at the end of a period or end of the game, the period or the game will not be ended. After the referee has done a VAR review and made the decision public, the referees will end the period or game.

2.3 An excluded player at the end of a period

When a player is excluded at the end of a period, and at the expiration of time the attacking team shoots at the goal, the VAR equipment must be used to assess if there was a change of possession in order to determine if the following period of the match will be restarted with both teams even, or with one player still excluded.

No other situations other than mentioned in 2.2 and 2.3 can be considered for VAR review after time expires.

2.4 Technical errors by jury table officials and / or malfunctioning of electronic equipment (game clock, shot clock, time-out devices)

In situations when technical errors of the table officials or malfunctioning of electronic equipment occurs, the referee may use the VAR system to determine the correct solution for the situation.

Determining and resolving the situation shall be made before the match is restarted.

2.5 Suspicion of an incident of violence

If the referee or VAR referee or delegate suspect that a violent action may have occurred, the referees may use VAR to review the situation:

- If the game is stopped at the moment of suspicion of violence
- if a violent action was determined, the referees will sanction the incident according to the rules and the game should recommence from the time of the incident.
- If a violent action was not determined, the game will proceed according to the rules.
- If the game was stopped at an appropriate moment and violent action was determined, all goals and personal fouls between the time of the incident and time of stoppage are then nullified, but all yellow and red cards, acts of violence and misconduct, will remain on the match protocol.

2.6 Interference during the taking of a penalty throw

In situations when the referees or VAR referee suspect interference during the taking of a penalty throw, the referees can use the VAR equipment to check the situation.

Based on the decision, the game continues from the appropriate moment as described in the rules.

3. REVIEW PROCESS

Step 1

A. The referee informs the VAR that a decision/incident should be reviewed (check).

B. The VAR official or delegate recommends to the referees that a decision/incident should be reviewed (check).

Step 2

The referees, if necessary, decide to stop the game to review the video at an appropriate moment (see E.4).

Step 3

Reviewing the doubtful situation on the VAR monitor.

Step 4

The referee communicates the final decision by going to the centre of the field of play and clearly indicating the decision and how the match will continue.

The Public Announcer must announce both the stoppage of the game to review the situation as well as the referee's decision after the review. A message may be displayed on the scoreboard as well.

Step 5

Restart of the game after the final decision.

4. POSITION OF THE PLAYERS DURING A VAR REVIEW

Players must remain in their respective halves of the field of play during the VAR review.

During any Video Review, no substitution is allowed from any of the re-entry areas before the referee communicates the decision after the Video Review.

The referee who is not reviewing VAR should control the players of both teams so that they can take up the correct positions in the field.

5. NO REASON FOR PROTEST

The result of a match should not be invalidated because of malfunction(s) of the VAR technology, wrong decision(s) involving the VAR, decision(s) not to review an incident or review(s) of a non-reviewable situation.

6. VIDEO REVIEW REQUEST

Post-match reviews will only be accepted on the request form provided by World Aquatics no later than 30 minutes after the game in which the incident occurred.

The TWPC does not review any incident if there is no official request from a team.

After the match a team, which was involved in the game may request a Video Review. This request may be done under the same conditions as filing a protest form after the match.

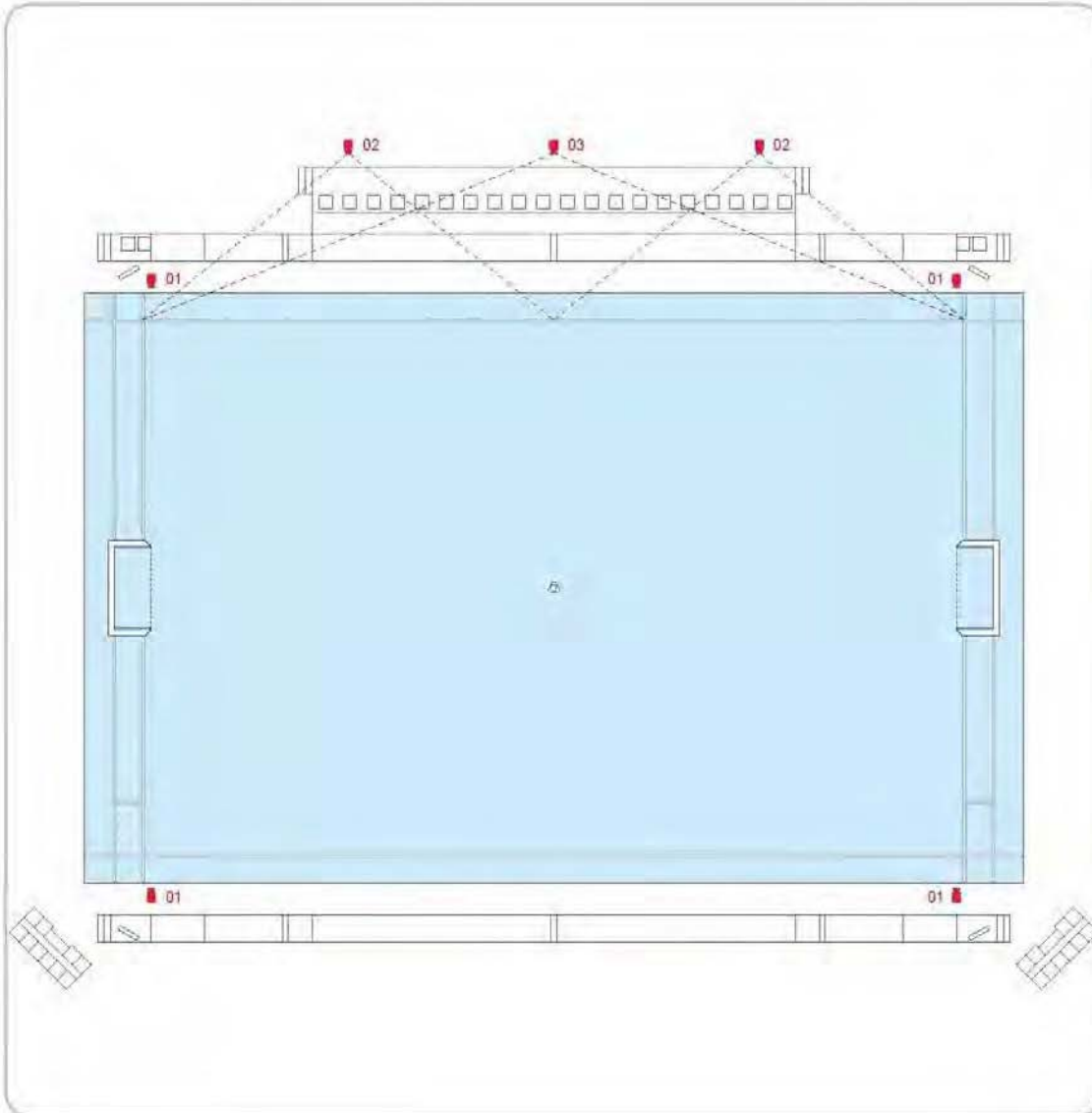

Cameras

1. Four cameras on the goal lines, two per goal. The location of the cameras should be at the edge of the pool or under referee's catwalk at about 1 m above the water level
2. Two cameras shall be fixed on the same side of the jury table. Each camera should film each a half of the field of play accordingly. The location of the cameras shall be that provide the best quality of video recording.
3. One camera is located at the side of the pool opposite to the benches. This camera shall film the entire field of play including both benches. This camera shall be capable to shoot at biggest possible angle (160 degrees is maximum today) with minimum resolution 2K pixels.

APPENDIX 8 - AGE GROUP TOURNAMENTS

1. All age group competitors remain qualified from 1 January to the following 31 December at their age at the close of day (12 midnight) on 31 December of the year of competition.

2. Age grouping for Water Polo for boys and girls are as follows:
 - 15 and 16 years of age and under (16U)
 - 17 and 18 years of age and under (18U)
 - 19 and 20 years of age and under (20U)

APPENDIX 9 - TOURNAMENT STRUCTURE

1. Water Polo Tournaments at Olympic Games and World Aquatics Championships

1.1. Olympic Games - Tournament Men

1.1.1 Draw

The draw for the Olympic Games Tournament will be either on the last day of the Olympic Games Qualification Tournament - Men or as otherwise determined and the following principle shall apply: if a team is already qualified by its ranking from a preceding qualification competition, the team will be placed on the highest line of the draw according to that ranking and the team taking its place will be placed on the lower line.

For the Preliminary Round, all qualifying teams will be drawn by pairs into two groups, either A or B.

First Line, the first and second placed teams from the previous World Championship will be drawn, one into A, and one into B.

Second Line, the team qualified from the preceding year's World League and the team representing the Continent of Europe will be drawn, one into A, and one into B.

Third Line, the teams representing the Continents of America and Oceania will be drawn, one into A, and one into B.

Fourth Line, the teams representing the Continents of Africa and Asia will be drawn, one into A, and one into B.

Fifth Line, the first and second placed teams from the Olympic Games Qualification Tournament - Men will be drawn, one into A, and one into B.

Sixth Line, the third placed team in the Olympic Games Qualification Tournament

1 Men and the team representing the Host Country will be drawn, one into A, and one into B.

Should there be no teams from the previous Championships to seed onto a Line then the highest ranked teams for Europe, Americas, Asia, Africa or Oceania if any, shall be drawn alternating between Group A and Group B.

After being divided into group A and group B, the teams will then be drawn with each team in each group receiving a separate number from one (1) to six (6).

1.1.2 Schedule of Games

Preliminary Round:

There will be two (2) groups of six (6) teams, which form groups A and B.

Each group will play a round robin. The four (4) highest ranked teams in each group will qualify for the Quarter Final Round. The fifth and

sixth ranked teams in each group will be eliminated and will not play anymore.

Day 1	Day 2	Day 3	Day 4	Day 5
1. A1-A6	7. B6 - B4	13. A4 - A5	19. B6 - B5	25. A5 - A1
2. A3-A4	8. B5 - B3	14. A2 - A6	20. B1 - B4	26. A3 - A6
3. A2-A5	9. B1 - B2	15. A3 - A1	21. B2 - B3	27. A4 - A2
4. B1-B6	10. A6 - A4	16. B4 - B5	22. A6 - A5	28. B3 - B6
5. B3-B4	11. A5 - A3	17. B2 - B6	23. A1 - A4	29. B4 - B2
6. B2-B5	12. A1 - A2	18. B3 - B1	24. A2 - A3	30. B1 - B5

Quarter Final Round:

The first, second, third and fourth placed teams in Group A and Group B form a Group D of eight (8) teams. Group D plays a modified single elimination format.

Games played in the Preliminary Round may be repeated in the Quarter Final, Semi Final or Final Round. All games played in Group D must be played so that a definite winner is declared. Accordingly, it may be necessary to apply the Water Polo Rules relating to penalty shoot-out.

Places 11 - 12

The teams ranked sixth in each group of the Preliminary Round shall be classified for places 11 - 12 according to the following criteria:

1. Win-loss record in their Preliminary Round group.
2. If both teams have the same win-loss record, the classification will be determined by goal average (goals scored divided by games played) taking into account the results of all games played in the respective group.

Places 9 - 10

The teams ranked fifth in each group shall be classified for places 9 - 10 according to the same principles as for places 11 - 12.

Day 6

31. 1A - 4B
32. 2A - 3B
33. 3A - 2B
34. 4A - 1B

Semi Final Round:

Day 7

- 35. L31 - L33
- 36. L32 - L34
- 37. W31 - W33
- 38. W32 - W34

Final Round:

Day 8

- 39. L35 - L36 (Winner 7th, Loser 8th)
- 40. W35 - W36 (Winner 5th, Loser 6th)
- 41. L37 - L38 (Winner 3rd, Loser 4th)
- 42. W37 - W 38 (Winner 1st, Loser 2nd)

Games 31 through 42 must be played to a conclusion, accordingly it may be necessary to apply Water Polo Rules relating to penalty shoot-out.

The Management Committee of World Aquatics Competitions may change the order and schedule of games to meet with the requirements of the Host Federation and/or television provided that at least twenty four (24) hours' notice is given.

1.2 Olympic Games - Tournament- Women

1.2.1 Draw

The Draw for the Olympic Games Tournament will be either on the last day of the Olympic Games Qualification Tournament – Women or as otherwise determined and the following principle shall apply: if a team is already qualified by its ranking from a preceding qualification competition, the team will be placed on the highest line of the Draw according to that ranking and the team taking its place will be placed on the lower line.

a) Group Draw

For the Preliminary Round, all qualifying teams will be drawn by pairs into two groups, either A or B.

First Line, the first placed team from the previous World Championship and the first team from the preceding year's World League will be drawn, one into A, and one into B.

Second line, the teams representing the Continents of Europe and Oceania will be drawn, one into A, and one into B.

Third line, the first and second placed teams from the Olympic Games Qualification Tournament - Women will be drawn, one into A, and one into B.

Fourth line, the team representing the Continent of America and the team representing the Continent of Asia will be drawn, one into A, and one into B.

Fifth line, the team representing the Continent of Africa and the team representing the Host Country will be drawn, one into A, and one into B.

b) Team Draw

After being divided into Group A and Group B, the teams will then be drawn with each team in each group receiving a separate number from one (1) to five (5).

1.2.2 Schedule of Games

Preliminary Round

Two (2) groups of five (5) teams form Group A and Group B and play a single round robin in each group.

Day 1	Day 2	Day 3	Day 4	Day 5
1. A5-A1	5. B1-B3	9. A5-A2	13. A2-A3	17. B3-B5
2. A2-A4	6. B4-B5	10. A3-A4	14. A4-A1	18. B1-B2
3. B5-B1	7. A4-A5	11. B3-B4	15. B2-B3	19. A3-A5
4. B2-B4	8. A1-A3	12. B5-B2	16. B4-B1	20. A1-A2

Quarter Final Round

The first, second, third and fourth placed teams in Group A and Group B form a Group D of eight (8) teams. Group D plays a modified single elimination format.

Games played in the Preliminary Round may be repeated in the Quarter Final, Semi Final or Final Round. All games played in Group D must be played so that a definite winner is declared. Accordingly, it may be necessary to apply the Water Polo Rules relating to penalty shoot-out.

Places 9 - 10

The teams ranked fifth in each group of the Preliminary Round shall be classified for places 9 - 10 according to the following criteria:

1. Win-loss record in their Preliminary Round group.

2. If both teams have the same win-loss record, the classification will be determined by goal average (goals scored divided by games played) taking into account the results of all games played in the respective group.

Day 6

- 21. 1A - 4B
- 22. 2A - 3B
- 23. 3A - 2B
- 24. 4A - 1B

Semi Final Round

Day 7

- 25. L21 - L23
- 26. L22 - L24
- 27. W21 - W23
- 28. W22 - W24

Final Round

Day 8

- 29. L25 - L26 (Winner 7th, Loser 8th)
- 30. W25 - W26 (Winner 5th, Loser 6th)
- 31. L27 - L28 (Winner 3rd, Loser 4th)
- 32. W27 - W28 (Winner 1st, Loser 2nd)

Games 21 through 32 must be played to a conclusion, accordingly it may be necessary to apply Water Polo Rules relating to penalty shoot-out.

The Management Committee of World Aquatics Competitions may change the order and schedule of games to meet with the requirements of the Host Federation and/or television provided that at least twenty four (24) hours' notice is given.

1.3 World Aquatics Championship – Men

1.3.1 Draw

The draw for the World Aquatics Championships Tournament will be made two (2) months prior to the commencement of the World

Aquatics Championships Tournament and the following principle shall apply: if a team is already qualified by its ranking from a preceding qualification competition, the team will be placed on the highest line of the draw according to that ranking and the team taking its place will be placed on the lower line.

For the Preliminary Round, all qualifying teams will be drawn into four (4) groups: A, B, C or D.

First Line, the first, second, third and fourth qualified teams from the preceding World Cup or Olympic Games will be drawn one into A, one into B, one into C, and one into D.

Second Line, the qualified teams from the World League (or from the World Cup or Olympic Games if applicable), the first qualified team from the Americas and the first qualified team from Europe will be drawn one into A, one into B, one into C, and one into D.

Third, the second qualified team from the Americas, the second and third qualified teams from Europe and the qualified team from Oceania will be drawn one into A, one into B, one into C, and one into D.

Fourth, the qualified team from Africa, the first and second teams from Asia and the Host Country (if the Host Country has already been drawn, then the next ranked team from the World Cup or Olympic Games) will be drawn one into A, one into B, one into C, and one into D.

After being divided into Groups A, B, C, or D, the teams will then be drawn with each team in each group receiving a separate number from one (1) to four (4).

1.3.2 Schedule of Games

Preliminary Round (First):

Four (4) groups of four (4) teams each from Group A, Group B, Group C and Group D play a single robin round in each group.

Day 1	Day 2	Day 3
1. A3 – A1	9. B4 - B3	17. C1 - C4
2. A2 - A4	10. B1 - B2	18. C2 - C3
3. B3 – B1	11. C4 - C3	19. D1 - D4
4. B2 - B4	12. C1 - C2	20. D2 - D3
5. C3 – C1	13. D4 - D3	21. A1 - A4
6. C2 - C4	14. D1 - D2	22. A2 - A3

7. D3 – D1

15. A4 - A3

23. B1 - B4

8. D2 - D4

16. A1 - A2

24. B2 - B3

Preliminary Round (Second):

The first placed teams in Group A, Group B, Group C and Group D have a bye.

The second and third placed teams in Group A, Group B, Group C and Group D play against each other in a cross group format. The fourth placed teams in each of Group A, Group B, Group C and Group D form a new Group which consists of four (4) teams. They play for places 13 – 16 in a cross group format.

Day 4

25. 4A - 4B

26. 4C - 4D

27. 2A – 3B

28. 3A – 2B

29. 2C – 3D

30. 3C – 2D

Quarter Final Round:

Day 5

31. Loser Game 25 - Loser Game 26
(Winner 15th, Loser 16th)

32. Winner Game 25 - Winner Game 26
(Winner 13th, Loser 14th)

33. Loser Game 27 - Loser Game 29

34. Loser Game 28 - Loser Game 30

35. 1A - Winner Game 29

36. 1B - Winner Game 30

37. 1C - Winner Game 27

38. 1D - Winner Game 28

Semi-Final Round:

Day 6

39. Loser Game 33 - Loser Game
(Winner 11th, Loser 12th)

40. Winner Game 33 - Winner Game 34
(Winner 9th, Loser 10th)

41. Loser Game 35 - Loser Game 36

42. Loser Game 37 - Loser Game 38

43. Winner Game 35 - Winner Game 36

44. Winner Game 37 - Winner Game 38

Final Round:

Day 7

45. Loser Game 41 - Loser Game
(Winner 7th, Loser 8th)

46. Winner Game 41 - Winner Game 42
(Winner 5th, Loser 6th)

47. Loser Game 43 - Loser Game 44
(Winner 3rd, Loser 4th)

48. Winner Game 43 - Winner Game 44
(Winner 1st, Loser 2nd)

Games 25 through 48 must be played to a conclusion, accordingly it may be necessary to apply the Water Polo Rules relating to penalty shoot-out.

The Management Committee of World Aquatics Competitions may change the order and schedule of games to meet with the requirements of the Host Federation and/or television provided that at least twenty four (24) hours' notice is given.

1.4 World Aquatics Championships - Women

1.4.1 Draw

The draw for the World Aquatics Championships Tournament will be made two (2) months prior to the commencement of the World Championships Tournament and the following principle shall apply: if a team is already qualified by its ranking from a preceding qualification competition, the team will be placed on the highest line of the draw according to its ranking and the team taking its place will be placed on the lower line.

For the Preliminary Round, all qualifying teams will be drawn into four (4) groups: A, B, C or D.

First Line, the first, second, third and fourth qualified teams from the preceding World Cup or Olympic Games will be drawn one into A, one into B, one into C, and one into D.

Second Line, the qualified teams from the World League (or from the World Cup or Olympic Games if applicable), the first qualified team from the Americas and the first qualified team from Europe will be drawn one into A, one into B, one into C, and one into D.

Third Line, the second qualified team from the Americas, the second and third qualified teams from Europe and the qualified team from Oceania will be drawn one into A, one into B, one into C and one into D.

Fourth Line, the qualified team from Africa, the first and second teams from Asia and the Host Country (if the Host Country has already been drawn, then the next ranked team from the World Cup or Olympic Games) will be drawn one into A, one into B, one into C, and one into D.

After being divided into Groups A, B, C, or D, the teams will then be drawn with each team in each group receiving a separate number from one (1) to four (4).

1.4.2 Schedule of Games

Schedule of Games as in Appendix 9 1.1.2

The Management Committee of World Aquatics Competitions may change the order and schedule of games to meet with the

requirements of the Host Federation and/or television provided that at least twenty four (24) hours' notice is given.

1.5 Olympic Games Qualification Tournament - Men

1.5.1 Draw

The draw for the Olympic Games Qualification Tournament will be made two (2) months or as otherwise determined prior to the commencement of the Olympic Games Qualification Tournament.

For the Preliminary Round, all qualifying teams will be drawn by pairs into two groups, either A or B.

First Line, the two highest placed teams from the previous World Championships.

Second Line, the next two highest placed teams from the previous World Championships.

Third Line, the next two highest placed teams from the previous World Championships.

Fourth Line, the next two highest placed teams from the previous World Championships.

Fifth Line, the remaining teams, if any, from the World Championships or the highest ranked teams from Europe and the next highest ranked teams from the Americas.

Sixth Line, the remaining teams, if any, being the next highest ranked team from the Americas, Asia or Europe and the next highest ranked team from the Americas, Asia or Europe.

Should there be no teams from the previous Championships to seed onto a Line then the highest ranked teams for Europe, Americas, Asia, Africa or Oceania if any, shall be drawn alternating between Group A and Group B.

After being divided into Group A and B, the teams will then be drawn with each team in each group receiving of separate number of 1 to 6.

1.5.2 Schedule of Games

Schedule of Games as in Appendix 9 1.1.2

The Management Committee of World Aquatics Competitions may change the order and schedule of games to meet with the requirements of the Host Federation and/or television provided that at least twenty four (24) hours' notice is given.

1.6 Olympic Games Qualification Tournament - Women

1.6.1 Draw

The draw for the Olympic Games Qualification Tournament will be made two (2) months or as otherwise determined prior to the commencement of the Olympic Games Qualification Tournament.

For the Preliminary Round, all qualifying teams will be drawn by pairs into two groups, either A or B.

First Line, the two highest placed teams from the previous World Championships.

Second Line, the next two highest placed teams from the previous World Championships.

Third Line, the next two highest placed teams from the previous World Championships.

Fourth Line, the next two highest placed teams from the previous World Championships.

Fifth Line, the remaining teams, if any, from the World Championships and the highest ranked teams from Europe, Americas, Asia, Africa or Oceania.

Sixth Line, the remaining teams, if any, shall be drawn alternating between Groups A and B.

Should there be no teams from the previous Championships to seed onto a Line then the highest ranked teams for Europe, Americas, Asia, Africa or Oceania if any, shall be drawn alternating between Group A and Group B.

After being divided into Group A and Group B, the teams will then be drawn with each team in each group receiving of separate number of 1 to 6.

1.6.2 Schedule of Games

Schedule of Games as in Appendix 9 1.1.2

The Management Committee of World Aquatics Competitions may change the order and schedule of games to meet with the requirements of the Host Federation and/or television provided that at least twenty four (24) hours' notice is given.

1.7 World U20 and U18 Championships – Men and women

1.7.1 Draw

The draw for the World U20 and U18 Championships will be made two (2) months prior to the commencement of the World Championships Tournament and the following principle shall apply: if a team is already qualified by its ranking from a preceding qualification competition, the team will be placed on the highest line of the draw according to its ranking and the team taking its place will be placed on the lower line.

Draw for twenty (20) Teams

The best 8 teams in the ranking from the previous World Championships (seeding) go in group A and B, and lower 12 teams in 4 groups C,D,E,and F.

1.7.2 Schedule of Games

Schedule for twenty (20) Teams

The best 8 teams in the ranking from the previous World Championships (seeding) go in group A and B, and lower 12 teams in 4 groups C,D,E,and F.

The numbers in the first 3 days are the position in the group after the draw. A and B groups have 4 teams and C,D,E,F groups have 3 teams.

First 3 days A and B group teams they play 3 games (round robin), while C,D,E,F they play 2 games (round robin).

The numbers from the day 4 are the ranking in the groups.

From the ranking of the groups C,D,E,F .the 2nd teams and the 3d teams of the groups C,D,E,F they play in 2 groups (G,H) a mixed round robin the days 4 to 6, and then 7and 8 days for places13-20. 1G-1H (13-14 place) 2G-2H (15-16), 3G-3H (17-18), 4G-4H (19-20)

Day 4, the first teams in the groups C,D,E,F they play against (1D-1C, 1E-1F) and the losers cross with 3d teams in Group A and B, while the winners cross with 4th teams in Group A and B.

The day 6 the winners of the 4 games they cross with first and seconds of Groups A and B (quarter finals) while the 4 losers they play for 9-12 places the days 7 and 8.

The days 7 and 8 we have semifinals and finals (1- 4 places) and also ranking from 5 to 8 places

The teams will play at least 6 games in the 8 days schedule and for the teams from 13-20 places to be able to play also the 2 last days.

Preliminary Round

Four (4) groups of three (3) teams each from Group C, Group D, Group E and Group F play a single robin round in each group. Upon the the result of the previous World Aquatics World Championships the top eight (8) teams will be drawn into two (2) group of fours (4), Group A and Group B.

DAY 1	DAY 2	SAY 3
1. C1-C3	9. D2-D3	17. E1-E2
2. D1-D3	10. E2-E3	18. F1-F2
3. E1-E3	11. F2-F3	19. C1-C2
4. F1-F3	12. C2-C3	20. D1-D2
5. A1-A3	13. B1-B2	21. A2-A3
6. B1-B3	14. A1-A2	22. B2-B3
7. A2-A4	15. B3-B4	23. A1-A4
8. B2-B4	16. A3-A4	24. B1-B4

Bye Day 1: C2 D2 E2 F2

Bye Day2 : C1 D1 E1 F1

Bye Day 3: C3 D3 E3 F3

Cross Overs:

The first placed teams in Group A, Group B have a bye.

DAY 4	DAY 5
25.2C-3D	31. 2E-2C
26.2E-3F	32. 3F-3D
27. 3C-2D	33. 3E-3C
28. 3E-2F	34. 2F-2D
29. 1D-1C	35. L29-3A
30. 1E-1F	36. L30-3B
	37. W29-4A
	38. W30-4B

Bye Day 4: A+B

Bye Day 5: 1A 2A 1B 2B

Quarter Final Round, Semi-Final Round and Final Round

DAY 6	DAY 7	DAY 8
39. 2C-3F	47. 4G-4H (19-20)	55. 2G-2H (15-16)
40. 2E-3D	48. 3G-3H (17-18)	56. 1G-1H (13-14)

41.3C-2F	49. L35-L38	57.L49-L50 (11-12)
42. 3E-2D	50.L36-L37	58. W49-W50 (9-10)
43. 1A-W38	51. L43-L46	59. L51-L52 (7-8)
44. 1B-W37	52. L44-L45	60. W51-W52 (5-6)
45. 2A-W36	53. W43-W46	61. L53-L54 (3-4)
46. 2B-W35	54. W44-W45	62. W53-W54 (1-2)

The Management Committee of World Aquatics Competitions may change the order and schedule of games to meet with the requirements of the Host Federation and/or television provided that at least twenty four (24) hours' notice is given.

GROUP A

GROUP B

A1	B1	C1	D1	E1	F1
A2	B2	C2	D2	E2	F2
A3	B3	C3	D3	E3	F3
A4	B4				
ê	ê	ê	ê	ê	
1A	1B	1C	2C	3C	
2A	2B	1D	2D	3D	
3A	3B	1E	2E	3E	
4A	4B	1F	2F	3F	

DAY 4,5,6

ROUND ROBIN	ROUND ROBIN
GROUP G	GROUP H
2C	3C
3D	2D
2E	3E
3F	2F

DAY 7,8 FOR PLACES 13-20

1G	1H
2G	2H
3G	3H
4G	4H

2. Draw for Competitions

The Management Committee for World Aquatics Competitions has the authority if there are only thirteen (13) or fourteen (14) participating teams to draw teams into two (2) groups rather than being required to draw teams in the prescribed manner for a competition based upon sixteen (16) teams, namely for (4) groups of four (4) teams each.

3. Order of Games

The Management Committee of World Aquatics Competitions may change the order and schedule of games to meet with requirements of the Host Federation and/or television provided that at least twenty four (24) hours' notice is given.

4. Officials

The Management Committee of World Aquatics Competitions may in addition to other officials appoint the following to assist in the conduct of any competition, namely: a World Aquatics TWPC Delegate, a World Aquatics TWPC Evaluator(s) and Timeout Officials.

1. BEACH WATER POLO RULES

1.1 FIELD OF PLAY

1.1.1 The distance between the goal line at each end of the field of play shall be fifteen (15) metres. The width of field of play shall be 10.0 – 12.5 metres.

1.1.2 The depth of the water of the playing area must not be less than two (2) metres.

1.1.3 Distinctive buoys shall be provided on both sides of the playing area:

Two (2) metre area red buoys

Five (5) metre area yellow buoys

remainder of the playing area green buoys

half distance line white buoys

1.1.4 Red buoys shall be placed at each end, two (2) metres from the corner of the playing area on the side of opposite to the official table to denote the touching corner.

1.1.5 The boundary of the field of play at each end shall be in line with the front of the goalpost.

1.1.6 The secretary shall be provided with separate white, blue, red, and yellow flags, each measuring 0.35 metres x 0.20 metres.

1.1.7 An area for flying substitutions must be available on the lateral outer side of the field of play, on the side where the team benches are situated. The width of this area, if segregated by lane ropes, must be between 0.5 metres – 1 metre. The designated area for flying substitutions for each team will be between the goal line in front of the team bench and the centre of the field of play.

1.1.8 The BWP Goal Area is defined by the space between the goal posts, extending out to the 2-metre line. (See rules 20.16.1, 20.17.3h

and 20.19.2).

20.2 GOALPOSTS

20.2.1 Two goalposts and crossbar rigidly constructed, rectangular with a dimension of 0.080 metres facing to the field of play and painted in any colour. The goals shall be located on the goal lines at each of the field of play end and equal distances from the sides. While rigidly constructed posts are preferred for World Aquatics events, inflatable posts are allowed for local tournaments.

20.2.2 The inner sides of the goal posts shall be 2.5 metres and the crossbar shall be 0.80 metres from the surface of the water.

20.2.3 The limp nets shall be securely fastened to the goal posts to prevent the ball from going underneath or through the side of net. The depth of the goals shall not be less than 0.30 metres.

20.3 THE BALL

20.3.1 The ball shall be round and shall have an air chamber with a self-closing valve. It shall be waterproof without external strapping or any covering of grease or similar substance.

20.3.2 The weight of the ball shall be not less than 400 grammes and not more than 450 grammes.

20.3.3 For the games played by men, the circumference of the ball shall be not less than 0.68 metres and not more than 0.71 metres, and its pressure shall be 7.5-8.5 pounds per square inch atmospheric.

20.3.4 For games play by women, the circumference of the ball shall be not less than 0.65 metres and not more than 0.67 metres, and pressure shall be 6.5-7.5 pounds per square inch atmospheric.

20.4 CAPS

20.4.1 Caps shall be of contrasting colours other than solid red, as approved by the referee, but also to contrast with the colour of the ball. A team may be required by the referee to wear white or blue caps. The goalkeepers shall wear red caps. Caps shall be fastened under the chin. Caps shall be fitted with malleable ear protectors which shall be the same colour as the team's caps except that the goalkeeper

may have red ear protectors.

20.4.2 Caps shall be numbered on both sides with 0.10 metres in height. The goalkeeper shall wear cap number one (1) and the other caps shall be numbered two (2) to seven (7).

20.4.3 A player who substitutes for the goalkeeper shall wear a red cap with the same number as he/she was wearing as a field player. A player shall not be allowed to change cap number during the game except with the permission of the referee and after notifying the secretary. Caps shall be worn throughout the entire game. If a player loses the cap during play, the player shall replace it at the next appropriate stoppage of the game when the player's team is in possession of the ball. The substituted goalkeeper shall wear cap No. 1 with the same colour of his/her team. Teams shall supply a set of red caps numbered 1-7, as well as a cap numbered one (1) in the same colour of his/her team.

20.4.4 For international games, the caps shall display the international three letter country code on the front and may display the national flag.

20.5 TEAMS AND SUBSTITUTES

20.5.1 Each team shall consist of four players, one of whom shall be the goalkeeper, and not more than three reserves who may be used as substitutes.

20.5.2 Two (2) officials namely the head coach or another official (Assistant Coach or Team Manager) are permitted to sit on the pontoon or similar designated area and shall not move away from there during the game. Up to two (2) other medical staff are permitted at a separate location away from the team bench.

20.5.3 Teams shall change ends at half time.

20.5.4 The substitutes' benches in beach water polo can be a pontoon and must be placed on the opposite side of the field of play from the referee and match officials.

20.5.5 Each team shall have a captain who shall be responsible for the behaviour of the team.

20.5.6 Players have to present themselves for matches with

fingernails properly cut and shall remove any articles that are likely to cause injury.

Players shall not have grease, oil or any similar or foreign substance on the body or hands. If the referee ascertains before the start of play that such a substance has been used, he shall order it to be removed immediately. If the offence is detected after the play has started, the offending player shall be excluded for remainder of the game with immediate substitution.

20.5.7 Each team shall have three substitutes who may participate in the game substituting a player. A substitute may enter the game from the touching corner as soon as the exiting player has visibly risen to the surface of the water in the touching corner and touched hands above the water with the substitute outside of the field of play. Substitution from the designated flying substitution area is allowed when the substitute enters the area from behind the extended goal line, both players, the exiting player, and the substitute, are in the water, outside of the field of play and touch hands above the water.

20.5.8 A goalkeeper who has been replaced by a substitute may play in any position.

20.5.9 After a goal, substitutions may be made from either the touching corner or flying substitution area after the goalkeeper has put the ball back into play. When substituting, both players need to be outside the field of play and make a visible high hand touch between the substituting players before entering the field of play.

20.5.10 The goalkeeper may touch the ball with two (2) hands inside the team's five (5) metre area.

20.5.11 No substitution is allowed when a penalty foul is called, and before the penalty throw is taken.

20.6 OFFICIALS

20.6.1 In all official competitions the match officials shall be as follows:

one referee

two secretaries

two timekeepers

20.6.2 The duties of the secretaries shall be:

to maintain the record of the game, including the players, the score, time outs, exclusion fouls and penalty fouls awarded against each player.

to signal with the red flag and whistle for any improper re-entry of an excluded player or substitute.

after three (3) minutes, the secretary should signal the re-entry of a substitute for a player who has committed brutality by raising the yellow flag along with the appropriate coloured flag.

to keep track of personal fouls, team fouls, and to indicate when a bonus penalty foul is called by a suitable audible signal (e.g., whistle or electronic signal). To record the time and the player's cap number when a goalkeeper is substituted.

to control the 'Alternating Possession System' for awarding free throws for neutral throw situations. (20.15.1).

20.6.3 The duties of the timekeeper shall be:

to record the exact periods of actual play, time outs and the intervals between the periods.

to record the periods of continuous possession of the ball by each team.

to announce the start of the last minute of the game.

to signal by whistle after 45 seconds and at the end of each time out.

20.6.4 A timekeeper shall signal by whistling (acoustically efficient and readily understood) the end of each period independently of the referee and the signal shall take immediate effect and stop the game except:

in the case of the simultaneous award by the referee of a penalty throw, in which event the penalty throw shall be taken.

if the ball is in flight and crosses the goal line, in which event any resulting goal shall be allowed.

20.7 REFEREE

20.7.1 The referee has absolute jurisdiction over the game, from the time the teams enter the playing area until they leave. All decisions are final and have to be accepted by all players and coaches. The referee may alter a decision, as long as this is done before the ball is back in play.

20.7.2 The referee shall whistle to start the game and to declare goals, goal throws, corner throws, neutral throws, and infringements of the rules.

20.7.3 The referee can apply the advantage rule so as not to favour the team that has committed the offence and should not stop play unless it is absolutely necessary.

20.7.4 The referee has the power to order any player from the water in accordance with the rules. If a player refuses to obey the referee's instructions, the match shall be abandoned and the game awarded five (5) goals to zero (0) to the opposing team.

20.7.5 The referee shall have the power to order the removal from the precincts of the pool any player, substitute, spectator or official whose behaviour prevents the referee from carrying out his or her duties in an impartial manner.

20.7.6 The referee shall have the power to abandon the game at any time if the referee believes that behaviour of players or spectators, or any other circumstances, prevent the match from taking place in a fair and correct manner. If the game has to be abandoned, the referee shall report their actions to the competent authority.

20.8 DURATION OF THE GAME

20.8.1 The duration of the game shall be four (4) periods of five (5) minutes each of actual play. Time shall commence at the start of each period when a player touches the ball. At all signals for stoppages, the recording watch shall be stopped until the ball is put back into play by the ball leaving the hand of the player taking the appropriate throw or when the ball is touched by a player following a neutral throw.

20.8.2 There shall be a two (2) minute interval between the 1st/2nd & 3rd /4th periods, and a three (3) minute interval at half time. The teams, including the players, coaches and officials, shall change ends at half time (20.5.3).

20.8.3 Every game that is drawn at the end of the four periods of play will be decided by conducting a penalty shoot-out in the same manner as the Water

Polo Rules. The goalkeeper can be one of the shooters. The goalkeeper can be substituted only when the goalkeeper is excluded for the remainder of the game for misconduct, violent action, or injury. Immediately after the goalkeeper is excluded, the substitute goalkeeper cannot have the goalkeeper's privileges for the first penalty throw taken after the offence.

the three players nominated will required to be listed in order and that order will determine the sequence, which cannot be changed.

no players excluded for remainder of the game are eligible to be listed among those players to shoot.

shots will be taken alternately at either end of the pool, unless conditions at one end of the field of play advantage or disadvantage a team, in which case all shots may be taken at the same end. All players taking the shots will remain in the water in front of their pontoon and the other players will be required to be seated on the team's pontoon. If the goalkeeper is excluded during the penalty shoot-out, a player from the nominated three players may substitute for the goalkeeper but without the privileges of the goalkeeper.

Following the taking of the penalty shot, the player may be substituted by another player or goalkeeper. If a field player is excluded during the penalty shoot-out, the player's position is removed from the list of the three players participating in the penalty shoot-out, and a substitute player is placed in the last position of the list.

the team to shoot first will be determined by the toss of a coin.

should teams still be tied following the completion of the initial three penalty shots, the same three players shall then take alternate shots until one team misses and the other scores.

20.8.4 Any visible clock shall show the time in descending manner.

20.8.5 If a game (or part of a game) must be replayed, then goals, personal fouls and time outs that occurred during the time to be replayed are deleted from the game score sheet, however brutality, misconduct, and any red card exclusions are recorded on the game score sheet.

20.8.6 (Mercy Rule) After half time, if the goal difference between the two team is 10 or more, the game will be declared finished and the leading team the winner.

20.9 TIME OUTS

20.9.1 Each team may request two timeouts per game.

20.9.2 A time out may be requested at any time by the coach of the team in possession of the ball except when a penalty foul is called. The coach shall call “time out” and signal to the referee or secretary with hands forming a T– shape. If a time out is requested, the secretary or referee shall immediately stop the game by whistle and players shall return to their respective halves of the field of play.

20.9.3 Play shall be restarted upon the whistle of the referee by the team in possession of the ball putting the ball into play on or behind the half distance line.

The possession clock continues from the recommencement of play after the time out.

20.9.4 If the coach in the possession of the ball requests an additional time out to which the team is not entitled, the game shall be stopped and play shall then be restarted by a player of opposing team putting the ball into play at the half distance line.

If the coach of the team not in possession of the ball requests a time out, the game shall be stopped and a penalty throw awarded to the opposing team.

20.10 THE START OF PLAY

20.10.1 The first team listed in the official program will wear white or light colour caps, or the caps reflecting the colour of their country and will start the game to the left of the official table. The other team will wear blue or dark colour caps, or caps of a contrasting colour and will start the game to the right of the official table.

20.10.2 At the start of each period, both teams will line up on their side of the playing area. When the referee is satisfied both teams are ready the referee shall blow the whistle to start and then throw the ball into play on the half distance line.

20.10.3 If the ball is thrown giving one team a definite advantage, the referee shall call for the ball and award a neutral throw on the half distance line.

20.11 SCORING

20.11.1 A goal shall be scored when the entire ball has passed fully over the goal line, between the goal posts and underneath the crossbar.

20.11.2 A goal can be scored with any part of the body except the clenched fist.

20.11.3 A goal can be scored from inside five (5) metres only if two players from either team intentionally play or touch the ball after the start of play.

20.11.4 A goal may be scored by a player by a shot from a free throw awarded and taken outside the five (5) metre area after fake or dribble or putting the ball on the water.

[Note: when the player is not shooting directly, the ball must be put in play as described in the rules before faking and dribbling]

20.11.5 A goal may be scored by a player after visibly putting the ball in play outside of five (5) metre line when the foul is called outside of five (5) metre line, goal throw (either directly or after putting the ball in play), or a free throw thrown by a player into the player's own goal.

20.11.6 A goal shall be scored if, at the expiration of twenty (20) seconds possession or at the end of a period, the ball is in flight and enters the goal.

20.12 RESTARTING AFTER A GOAL

20.12.1 The goalkeeper shall put the ball into play from the two (2) metre line or behind immediately after a goal has been scored. The timekeeper shall stop the game clock after a goal is scored, and will restart it when the ball is put into play for restart.

20.13 GOAL THROW

20.13.1 A goal throw shall be awarded when the entire ball has passed fully over the goal line excluding between the goal posts and underneath the crossbar, having last been touched by any player.

20.13.2 The goal throw shall be taken by any player of the team from anywhere within the 2metre area.

20.14 CORNER THROW

20.14.1 No corner throws shall be applied in Beach Water Polo.

20.15 NEUTRAL THROW

No neutral throws shall be taken, and if neutral throw situation occurs, "The Alternating Possession System" shall be applied in the following way:

The team that wins the swim-up of the first period loses the first neutral throw.

For subsequent neutral throw situations, free throws shall be awarded to the teams alternately. The team entitled to the next free throw shall be indicated by the alternating possession arrow in the direction of the opponent's goal. The direction of the alternating possession arrow shall be reversed immediately when the alternating possession free throw is taken.

20.16 FREE THROW

20.16.1 A free throw shall indicate that a foul has been committed. The free throw shall be taken from the location of the ball, except a) if the foul is committed by a defending player within the defender's BWP Goal Area, the free throw shall be taken on the two (2) metre line opposite to where the foul was committed and b) where otherwise provided for in the Rules.

20.16.2 The free throw shall be taken from the location of the ball by the player of the team who is the nearest to the ball. When there is a counter attack, a player with advantage does not have to give up the advantage to go to the ball and take the free throw or goal throw. Another player of that team can take the throw as long as there is no undue delay.

20.16.3 The free throw must be taken in such a manner so as to enable all the other players to see that the throw has been taken. The player can either throw the ball up into the air or let it fall on to the water.

20.16.4 The time allowed for a player to take a free throw shall be at the discretion of the referee. It shall be reasonable and without undue delay but does not have to be immediate. It shall be an offence if a player who is clearly in a position most readily to take a free throw does not do so.

20.17 ORDINARY FOULS

20.17.1 The penalty for an ordinary foul shall be a free throw awarded to the opposing team.

20.17.2 The referee must award ordinary fouls in accordance with the rules to enable the attacking team to develop an advantage situation.

20.17.3 It shall be an ordinary foul to commit any of the following offences:

- a)** to start the swim off before the referee's whistle is blown;
- b)** to assist or push a player at the start of a period or at any time during the game;
- c)** to hold on or push off equipment or structures around the field of play or the goal posts;
- d)** To take or hold the entire ball under the water when tackled, or to deliberately hide it from the opposing team
- e)** to touch the ball with two hands at the same time, except for the goalkeeper within the team's own five (5) metre area;
- f)** to push or push off from an opponent who is not holding the ball;
- g)** for another member of the team in whose favor a free throw has been awarded to commit another ordinary foul before the free throw is taken;
- h)** during the game, players are free to take up any position in the field of play with the exception that no attacking player may enter the space between the goal posts and closer than two (2) metres from the goal line, with or without the ball (the BWP Goal Area).
- i)** to take a penalty throw not in accordance with the manner prescribed in 20.20.5.
- j)** to send the ball over the buoys delineating the sides of the field of play (the ball remains in play if it just touches the sides of the field of play);
- k)** for a goalkeeper to touch the ball with two hands at the same time outside the goalkeeper's five (5) metre area;
- l)** for a team to retain possession of the ball for more than twenty (20) seconds of actual play without shooting at their opponent's goal. The timekeeper recording the possession time shall reset the clock: when the ball has left the hand of the player shooting at goal. If the ball rebounds into play from the goal, crossbar or the goalkeeper, the possession time shall not:
 - m)** recommence until the ball comes into the possession of one of the teams;
 - n)** when the ball comes into the possession of the opposing team. Possession shall not include merely being touched in flight by an opposing player;
 - o)** when the ball is put into play following the award of an

exclusion foul, penalty foul, goal throw, corner throw or neutral throw:

p) Visible clocks shall show the time in a descending manner (show the possession time remaining).

q) To simulate being fouled. [NOTE: Simulation means an action taken by a player with the apparent intent of causing a referee to award a foul incorrectly against an opposing player. A referee may issue a yellow card against a team for repeated simulation and may apply WP 9.13 (persistent fouling) to sanction offending players.]

r) To go under the water to gain positional advantage.

20.18 EXCLUSION FOULS

20.18.1 It shall be an exclusion foul to commit any of the following offences which shall be punished (except in the case of penalty throw) by the award of a free throw to the opposing team. The excluded player shall touch that part of the goal line indicated by red buoy and re-join play immediately. A penalty will be awarded against the team of that player who, when leaving the playing area after being excluded, interferes with play. The excluded player may be substituted by leaving the field of play at that part of the goal line indicated by the red buoy (the touching corner). The substitute may enter the field of play from the touching corner as soon as the player has visibly risen to the surface of the water within the touching corner area and touched hands above the water with the substitute.

20.18.2 For a player to leave the water during play, except in the case of accident, and injury, or with the permission of the referee.

20.18.3 To interfere with the taking of a free throw or goal throw intentionally pushing the ball away to delay the throw

any attempt to play the ball before it leaves the hand of the player taking the throw

20.18.4 To intentionally splash water in the face of an opponent outside the five (5) metre line. The punishment for intentionally splashing an opponent is exclusion under 20.18.1

20.18.5 To hold, sink or pull back an opponent who is not holding the ball.

20.18.6 To impede an opponent's movement who is not in possession of the ball.

20.18.7 To kick or strike an opponent intentionally or make disproportionate movement with that intent.

20.18.8 Upon a change of possession, for a defending player to commit a foul on any player of the team in possession of the ball with the intent to stop the flow of the attack, anywhere in the field of play. This kind of foul is called a tactical foul.

20.18.9 To be guilty of misconduct, including the use of unacceptable language, violent or persistent foul play, to refuse obedience or show disrespect to the referee or official, or behaviour against the spirit of the rules and likely to bring the game into disrepute. While substitution for a player who has been excluded for the remainder of the game due to misconduct can be made immediately in BWP rules, the player who has been excluded for the remainder of the game due to misconduct will have to leave the field of play from the touching corner first, and then the substitute can enter the field of play immediately thereafter.

20.18.10 To commit a violent action against an opponent or official, during the game. The offending player shall be excluded from the remainder of the game with substitution after three (3) minutes and a penalty throw awarded to the opposing team.

No penalty throw shall be awarded against a violent action committed during an interval or stoppage.

20.18.11 For an excluded player to re-enter or a substitute to enter the playing area improperly, including:

from any place other than the player's own re-entry

area by affecting the alignment of the goal

entering the field of play before the player who is being substituted leaves the field of play

20.18.12 To interfere with the taking of a penalty throw, in which case the player excluded can only re-enter the field of play after the penalty throw has been taken. Players have to be at least three (3) metres away from the player taking the penalty throw.

20.18.13

The defending goalkeeper, after having been warned by the referee, for not positioning correctly on the goal line before the taking of a penalty throw. Another defending player may take the position of the goalkeeper but without the privileges of the goalkeeper.

A goalkeeper who is excluded before a penalty throw, cannot return to the field of play immediately after touching the corner area, but has to leave the field of play and wait in the touching corner. The goalkeeper shall be able to return to play only after the penalty shot has been taken, which means the ball is released from the thrower's hand.

20.18.14

If two players from opposing sides commit simultaneous exclusion fouls, both players will be excluded. The ball possession will be maintained, and the attacking team shall restart the game with a free throw. Possession time shall be maintained and shall not be reset. The game will restart when both of the excluded players have returned to their touching corners. Both players or substitutes will then be allowed to return to the field of play upon a change of the possession, or after a goal. If the excluded players are substituted, substitutions have to be made outside of field of play at the touching corner after touching hands with the both players.

20.18.15 A player who has committed five (5) personal fouls shall be excluded for the remainder of the game

20.19 PENALTY FOULS

20.19.1 It shall be a penalty foul to commit any of the following offences which shall be punished by award of a penalty throw to the opposing team. The referee will indicate that a penalty throw has been awarded by blowing the whistle and raising the arm with five fingers. The referee must delay the call of penalty until the shot or attempted shot is completed. In such case, the referee may raise his/her arm indicating a possible penalty.

20.19.2 For a defending player to commit any foul within the five (5) metre area but for which a goal would probably have resulted, including:

sink or displace the goals

for a defending player to play the ball with clenched fist

for the goalkeeper or another player to take the ball under the water when tackled within 5m area but outside the BWP Goal Area

to splash in the face of an opponent intentionally who is inside the five (5) metre area and is attempting to shoot at goal.

20.19.3 For a defending player within the 5-metre area to kick or strike an opponent or to commit a violent action. In the case of a violent action, the offending player shall also be excluded from the remainder of the game with substitution after three (3) minutes.

20.19.4 For an excluded player intentionally to interfere with play, including affecting the alignment of the goal.

20.19.5 For a player or substitute who is not entitled under the Rules to participate in the play at that time to enter the field of play. The offending player shall also be excluded from the remainder of the game with substitution.

20.19.6 For the coach, any team official, or player to take any action with intent to prevent a probable goal or to delay the game, including:

If a defending player deliberately throws the ball away before the attacking team can take a free throw

If a defending player, after a free throw outside the five (5) metre line, deliberately pushes the ball inside five (5) metre line, to avoid a direct shot.

No personal foul shall be recorded for this offence for the coach or any team official.

20.19.7 For a player or substitute, of the team not in possession of the ball, to enter the field of play improperly.

20.19.8 If, in the last minute of the game a penalty throw is awarded to a team, the coach may elect to maintain possession of the ball and be awarded a free throw. The timekeeper recording possession time shall reset the clock.

20.19.9 Inside the 5 metre area, when a player, in a “probable goal situation”, is swimming with and/or is holding the ball and is impeded (attacked) from behind during an attempt to shoot, a penalty foul must be awarded. [Note: unless only the ball is touched by the defender]

20.19.10 Bonus penalty throws shall be awarded at every 4th personal foul (Team Fouls) per period. At the fourth personal foul per team in a period, a bonus penalty throw shall be awarded to the other team, and the player who has committed the foul shall move to touching corner of the player’s team outside the field of play until the penalty throw is taken. In this case, no substitution shall be allowed before the penalty throw is taken. If the 4th personal foul is a penalty foul, only 1 penalty throw shall be awarded to the other team. If the penalty throw results in a goal, the team who has taken the penalty throw shall be allowed to have a new consecutive possession of the ball starting in the same manner as restart after a timeout (20.9.3). If the penalty throw does not result in a goal, the play shall continue.

20.20 PENALTY THROWS

20.20.1 A penalty throw can be taken by any player of the team in favour of which the throw has been awarded. The penalty throw is taken from the five (5) metre line.

20.20.2 The defending goalkeeper shall be positioned between the goalposts with no part of the body beyond the goal line at water level.

20.20.3 All players except the player who has committed the penalty foul shall leave the five (5) metre area and shall be at least three (3) metres from the player taking the penalty throw. A player who has committed a penalty foul shall move to their team's touching corner inside of the field of play until the penalty throw is taken.

20.20.4 The referee, after seeing that all the players are in correct position, will order the taking of the penalty throw in the following manner: The raised arm will mean ready to shoot and by bringing the referee's arm from vertical to horizontal position and blowing the whistle simultaneously. The lowering of the arm at the same time as the signal by whistle makes it possible under any conditions to execute the penalty throw in accordance with the rules.

20.20.5 The player taking the penalty throw shall have possession of the ball and shall immediately throw it with an uninterrupted movement directly at the goal. The player may take the throw by lifting the ball from the water or with the ball held in the raised hand and the ball may be taken backwards from the direction of the goal in preparation for the forward throw, provided that the continuity of movement shall not be interrupted before the ball leaves the thrower's hand.

20.20.6 If the ball rebounds from the goalpost crossbar or goalkeeper, it remains in play and it shall not be necessary for another player to play or touch the ball before a goal can be scored.

20.20.7 If, at precisely the same time as the referee awards a penalty throw, the timekeeper whistles for the end of a period, all players except the player taking the penalty throw and the defending goalkeeper shall leave the water before the penalty throw is taken. In this situation, the ball shall immediately be dead should it rebound into the field of play.

20.21 ACCIDENT AND INJURY

20.21.1 A player shall only be allowed to leave the water during play in the case of accident or injury or with the permission of the referee. A player who has left the water legitimately may re-enter from the re-entry area nearest the player's own goal line at an appropriate stoppage and with the permission of the referee.

20.21.2 If a player is bleeding, the referee shall immediately order the player out of the water with the immediate entry of a substitute. After the bleeding has stopped, the player is permitted to be a substitute in the ordinary course of the game.

20.21.3 If accident or injury, other than bleeding, occurs, the referee, at the referee's discretion, may suspend the game for not more than three minutes, in which case the referee

shall instruct the timekeeper as to when the stoppage period is to commence. Except in the circumstances of 20.21.2 (bleeding), the player shall not be allowed to take further part in the game if a substitute has entered.

20.22 PERSONAL FOULS

20.22.1 A personal foul shall be recorded against any player who commits an exclusion foul or penalty foul. The referee shall indicate the offending player's cap number to the secretary.

20.22.2 Upon receiving a fifth (5th) personal foul, a player shall be excluded from the remainder of the game with substitution after they reach the touching corner outside of the field of play, having touched hands with each other.

20.22.3 When a team accumulates four (4) personal fouls in any period of a game, a penalty throw shall be awarded, and the accumulated Team Fouls shall then be cancelled and recounted (as stipulated in 20.19.10).

20.23 YELLOW AND RED CARDS

20.23.1 The referee, if necessary, must use Yellow and Red Cards to control the Team Officials and Substitute Players on the Team Bench as well as the players in the water. The use of Yellow and Red Cards applies to all World Aquatics Water Polo Competitions and will be administered as follows;

The issuing of a Yellow Card by the referee is an official warning to the Head Coach of the team.

The subsequent issuing of a Red Card by the referee is the signal that the Head Coach and/or other Team Official(s) and/or player(s) on the bench must leave pool area immediately. Should the actions of the Head Coach require it, the referee may issue a Red Card, without having issued a Yellow Card.

When the Head Coach is excluded from the game, another Team Official may take this position, however without the privileges of the Head Coach. The Team Official is not allowed to stand and move away from the team bench but can ask for a time-out according to the rules. During a time out or after a goal, before the restart of the match the Team Official may move freely along the poolside till the halfway mark to instruct the team.

During the match, when a team member inside the water commits an act of misconduct, the referee must show a Red Card to the player accompanied by the appropriate sanction.

A referee may issue a Yellow Card, if, in the referee's opinion, a player persists in playing in an unsporting manner or engages in simulation. (WP 8.14). The referee shall show a Yellow Card to the offending team and point to the offending player. Should the action continue, the referee will show the player a Red Card visible to both the team and the table as this is deemed to be misconduct. (as per WP 9.13)

Team members committing an act of misconduct will be punished according to VI.9.13 and must leave the pool area immediately.